

EAC-5000 USER

NVIDIA® Jetson AGX Orin™ Edge AI Computing System
6 GigE LAN with 4 PoE+, 8 GMSL2, 1 PCIe x8, -25°C to 70°C Operation

Manual

Record of Revision

Version	Date	Page	Description	Remark
1.00	2023/08/17	All	Official Release	
1.10	2023/10/18	56	Update	
1.20	2024/02/06	All	Update	
1.30	2024/04/10	32, 38	Update	
1.40	2024/09/11	All	Update	

Disclaimer

This manual is released by Vecow Co., Ltd. for reference purpose only. All product offerings and specifications are subject to change without prior notice. It does not represent commitment of Vecow Co., Ltd. Vecow shall not be liable for direct, indirect, special, incidental, or consequential damages arising out of the use of the product or documentation or any infringements upon the rights of third parties, which may result from such use.

Declaration of Conformity

FCC This equipment has been tested and found to comply with the limits for a Class A digital device, pursuant to part 15 of the FCC Rules. These limits are designed to provide reasonable protection against harmful interference when the equipment is operated in a commercial environment. This equipment generates, uses, and can radiate radio frequency energy, and if it is not installed and used in accordance with the instruction manual, it may cause harmful interference to radio communications. Operation of this equipment in a residential area is likely to cause harmful interference in which case the user will be required to correct the interference at his own expense.

CE The products described in this manual complies with all applicable European Union (CE) directives if it has a CE marking. For computer systems to remain CE compliant, only CE-compliant parts may be used. Maintaining CE compliance also requires proper cable and cabling techniques.

Copyright and Trademarks

This document contains proprietary information protected by copyright. No part of this publication may be reproduced in any form or by any means, electric, photocopying, recording or otherwise, without prior written authorization by Vecow Co., Ltd. The rights of all the brand names, product names, and trademarks belong to their respective owners.

Order Information

Part Number	Description
EAC-5000-R64	EAC-5000, on-board 64GB RAM, 2 LAN, 5 USB 3.1, 2 COM RS-232/422/485, 2 Isolated CAN Bus, 16 Isolated DIO, 1 PCIe Gen3 x8, 8 Fakra-Z connectors for GMSL 1/2 automotive cameras
EAC-5000-R32	EAC-5000, on-board 32GB RAM, 2 LAN, 5 USB 3.1, 2 COM RS-232/422/485, 2 Isolated CAN Bus, 16 Isolated DIO, 1 PCIe Gen3 x8, 8 Fakra-Z connectors for GMSL 1/2 automotive cameras
EAC-5000-OOB-R64	EAC-5000, on-board 64GB RAM, on-board OOB Moulde, 2 GigE LAN, 1 OOB LAN, 5 USB 3.1, 2 COM RS-232/422/485, 2 Isolated CAN Bus, 16 Isolated DIO, 1 PCIe Gen3 x8, 8 Fakra-Z connectors for GMSL 1/2 automotive cameras
EAC-5000-OOB-R32	EAC-5000, on-board 32GB RAM, on-board OOB Moulde, , 2 GigE LAN, 1 OOB LAN, 5 USB 3.1, 2 COM RS-232/422/485, 2 Isolated CAN Bus, 16 Isolated DIO, 1 PCIe Gen3 x8, 8 Fakra-Z connectors for GMSL 1/2 automotive cameras
EAC-5100-R64	EAC-5100, on-board 64GB RAM, 6 LAN with 4 PoE+, 5 USB 3.1, 2 COM RS-232/422/485, 2 Isolated CAN Bus, 16 Isolated DIO, 1 PCIe Gen3 x8
EAC-5100-R32	EAC-5100, on-board 32GB RAM, 6 LAN with 4 PoE+, 5 USB 3.1, 2 COM RS-232/422/485, 2 Isolated CAN Bus, 16 Isolated DIO, 1 PCIe Gen3 x8
EAC-5100-OOB-R64	EAC-5100, on-board 64GB RAM, on-board OOB Moulde, 6 LAN with 4 PoE+, 1 OOB LAN, 5 USB 3.1, 2 COM RS-232/422/485, 2 Isolated CAN Bus, 16 Isolated DIO, 1 PCIe Gen3 x8
EAC-5100-OOB-R32	EAC-5100, on-board 32GB RAM, on-board OOB Module, 6 LAN with 4 PoE+, 1 OOB LAN, 5 USB 3.1, 2 COM RS-232/422/485, 2 Isolated CAN Bus, 16 Isolated DIO, 1 PCIe Gen3 x8

Optional Accessories

Part Number	Description
PWA-160WB-WT	160W, 24V, 85V AC to 264V AC Power Adapter with 3-pin Terminal Block, Wide Temperature -30°C to +70°C
PWA-180WB	180W, 24V, 90V AC to 264V AC Power Adapter with 3-pin Terminal Block
PWA-280WB-WT	280W, 24V, 85V AC to 264V AC Power Adapter with 3-pin Terminal Block, Wide Temperature -30°C to +70°C
VESA Mount	VESA Mounting Kit
DIN-RAIL	DIN Rail and VESA Mounting Kit
GMSL Camera Kit	GMSL Camera with Fakra-Z connector
M.2 Storage Module	M.2 Key M/Key B PCIe Storage Module
5G Module	5G Module with Antenna
4G Module	4G/GPS Module with Antenna
WiFi & Bluetooth Module	WiFi & Bluetooth Module with Antenna

Table of Contents

CHAPTER 1	GENERAL INTRODUCTION	1
1.1	Overview	1
1.2	Features	2
1.3	Product Specification	3
1.3.1	Specifications of EAC-5000	3
1.3.2	Specifications of EAC-5000-OOB	5
1.3.3	Specifications of EAC-5100	7
1.3.4	Specifications of EAC-5100-OOB	9
1.4	Mechanical Dimension	11
1.4.1	Dimensions of EAC-5000	11
1.4.2	Dimensions of EAC-5000-OOB	11
1.4.3	Dimensions of EAC-5100	12
1.4.4	Dimensions of EAC-5100-OOB	12
CHAPTER 2	GETTING TO KNOW YOUR EAC-5000/EAC-5100	13
2.1	Packing List	13
2.2	Front Panel I/O & Functions	14
2.3	Rear Panel I/O & Functions	24
2.4	Main Board Connector & Jumper Locations	30
2.5	Main Board Jumper Settings	37
2.6	Ignition Control	40
CHAPTER 3	SYSTEM SETUP	42
3.1	How to Open Your EAC-5000/EAC-5100	42
3.2	Installing Nano SIM Card	43
3.3	Installing Micro SD Card	44
3.4	Installing PCIe Card	45

3.5	Installing M.2	47
3.6	Installing Antenna Cable	50
3.7	Mounting Your EAC-5000/EAC-5100	51
CHAPTER 4	SOFTWARE SETUP	53
4.1	Peripheral Interface Guide	53
4.2	Flash image to Your EAC-5000/EAC-5100	53
4.3	Software Ignition Control	55
4.4	Enable OOB Management Services	56
4.5	Troubleshooting Your OOB Enabler	57
APPENDIX A	GMSL Camera Guide(EAC-5000 Only)	58
APPENDIX B	Power Consumption	59
APPENDIX C	Supported Expansion Module List	61

1

GENERAL INTRODUCTION

1.1 Overview

The Vecow EAC-5000/5100 is an Arm-based Edge AI Computing System. Powered by the NVIDIA® Jetson AGX Orin™ system-on-module, the Vecow EAC-5000/5100 delivers great power efficiency in a small form factor. Featuring 8 GMSL 1/2 automotive cameras via rugged FAKRA-Z connectors, the series is well-suited for industrial and outdoor environments. The EAC-5000/5100 is available in four models: EAC-5000, EAC-5000-OOB, EAC-5100, and EAC-5100-OOB. The EAC-5000-OOB and EAC-5100-OOB models are integrated with OOB (Out-of-Band) remote management operation technology, bringing powerful disaster recovery service to Edge AI applications.

The Vecow EAC-5000/5100 is based on the NVIDIA Jetson AGX Orin platform, which features an Arm® Cortex®-A78AE CPU delivering up to 275 TOPS of AI performance. It integrates an advanced NVIDIA Ampere architecture GPU with 64 Tensor Cores, capable of delivering server-class performance for edge AI applications.

With support for operating temperature from -25°C to 70°C, 9V to 50V wide range DC-in, along with GMSL1/GMSL2 automotive cameras supported by MAXIM MAX9296 via FAKRA-Z connectors, the Vecow EAC-5000/5100 brings small size and easy deployment of AI vision and industrial applications, including In-Vehicle Computing, Robotic Control, Medical Imaging, Public Security, Smart Factory, AMR/AGV, and any AIoT/Industry 4.0 applications.

1.2 Features

- Advanced NVIDIA® Jetson AGX Orin™ platform delivers up to 275 TOPS AI performance
- The latest NVIDIA Ampere™ architecture, featuring with 2048 NVIDIA® CUDA® cores and 64 Tensor cores
- Supports 8 GMSL 1/2 automotive cameras with Fakra-Z connectors
- 1 PCIe Gen3 x8 expansion slot supports optional multiple 10GigE/PoE LAN/USB connections
- 6 GigE LAN with 4 PoE+, 1 Digital Display supports 4K60
- 2 Isolated CAN Bus support Flexible Data-rate, 2 COM RS-232/422/485, 5 USB 3.1
- Supports device remote management by Allxon
- DC 9V to 50V wide range power input, Ignition Power Control

1.3 Product Specification

1.3.1 Specifications of EAC-5000

System	
Processor	NVIDIA® Jetson AGX Orin™ System-On-Module <ul style="list-style-type: none"> • 12-core Arm® Cortex®-A78AE v8.2 64-bit CPU • 2048-core NVIDIA Ampere™ architecture GPU with 64 Tensor Cores
Memory	R32 : 1 32GB LPDDR5 DRAM R64 : 1 64GB LPDDR5 DRAM
Storage	eMMC 5.1, 64 GB
Software Support	<ul style="list-style-type: none"> • Linux • NVIDIA JetPack SDK
Ethernet	
LAN 1 to LAN 2	10/100/1000 Base-T Ethernet GigE LAN, RJ45 Connector (Optional X-coded M12 Connector)
Graphics	
Interface	1 Digital Display, up to 4K60
Video Encode	<ul style="list-style-type: none"> • R32 : 1x 4K @60, 3x 4K @30, 6x 1080p @60, 12x 1080p @30 (HEVC) • R64 : 2x 4K @60, 4x 4K @30, 8x 1080p @60, 16x 1080p @30 (HEVC)
Video Decode	<ul style="list-style-type: none"> • R32 : 1x 8K @30, 2x 4K @60, 4x 4K @30, 9x 1080p @60, 18x 1080p @30 (HEVC) • R64 : 1x 8K @30, 3x 4K @60, 7x 4K @30, 11x 1080p @60, 22x 1080p @30 (HEVC)
Camera	
GMSL	8 Fakra-Z connectors for GMSL 1/2 automotive cameras
I/O Interface	
USB	<ul style="list-style-type: none"> • 1 USB 3.2 Gen2 • 4 USB 3.1
Serial	2 COM RS-232/422/485
CAN Bus	2 Isolated CAN Bus support CAN FD
DIO	16 Isolated DIO (8 DI, 8 DO)
Button	<ul style="list-style-type: none"> • 1 Power Button • 1 Force Recovery Button • 1 Reset Button
Micro USB	<ul style="list-style-type: none"> • 1 Micro USB console debug port • 1 Micro USB OS flash port
SIM	2 SIM Card Socket
LED	Power, HDD, 2 User Programming
Antenna	6 Antenna for 5G/WiFi/4G/LTE/GPRS/UMTS

Expansion	
PCIe	1 PCIe x16 slot with PCIe 3.0 x8 signal
M.2	<ul style="list-style-type: none"> • 1 M.2 Key B Socket (3042/3052, USB3) • 1 M.2 Key E Socket (2230, PCIe/USB2)
Storage	
SD	1 Micro SD Socket (External)
M.2	2 M.2 Key M Socket (2280, PCIe Gen3 x4)
eMMC	1 eMMC 5.1, 64GB
Power	
Power Input	DC 9V to 50V
Power Interface	3-pin Terminal Block : V+, V-, Frame Ground
Ignition Control	16-mode Software Ignition Control
Remote Switch	3-pin Remote Switch Terminal Block
Mechanical	
Dimensions	260 mm x 182 mm x 69 mm (10.24" x 7.17" x 2.72")
Weight	3.8 kg (8.39 lb)
Mounting	<ul style="list-style-type: none"> • Wallmount • DIN Rail and VESA Mount (Optional)
Environment	
Operating Temperature	30W TDP Mode : -25°C to 70°C (-13°F to 158°F) 40/50W TDP Mode : -25°C to 55°C (-13°F to 131°F)
Storage Temperature	-40°C to 85°C (-40°F to 185°F)
Humidity	5% to 95% Humidity, non-condensing
Relative Humidity	95% at 70°C
Shock	Operating, MIL-STD-810G, Method 516.7, Procedure I
Vibration	Operating, MIL-STD-810G, Method 514.6, Procedure I, Category 4
EMC	CE, FCC, EN50155, EN50121-3-2, EN62368-1

1.3.2 Specifications of EAC-5000-OOB

System	
Processor	NVIDIA® Jetson AGX Orin™ System-On-Module <ul style="list-style-type: none"> • 12-core Arm® Cortex®-A78AE v8.2 64-bit CPU • 2048-core NVIDIA Ampere™ architecture GPU with 64 Tensor Cores
Memory	R32 : 1 32GB LPDDR5 DRAM R64 : 1 64GB LPDDR5 DRAM
Storage	eMMC 5.1, 64 GB
Software Support	<ul style="list-style-type: none"> • Linux • NVIDIA JetPack SDK
Ethernet	
LAN 1 to LAN 2	10/100/1000 Base-T Ethernet GigE LAN, RJ45 Connector (Optional X-coded M12 Connector)
Graphics	
Interface	1 Digital Display, up to 4K60
Video Encode	<ul style="list-style-type: none"> • R32 : 1x 4K @60, 3x 4K @30, 6x 1080p @60, 12x 1080p @30 (HEVC) • R64 : 2x 4K @60, 4x 4K @30, 8x 1080p @60, 16x 1080p @30 (HEVC)
Video Decode	<ul style="list-style-type: none"> • R32 : 1x 8K @30, 2x 4K @60, 4x 4K @30, 9x 1080p @60, 18x 1080p @30 (HEVC) • R64 : 1x 8K @30, 3x 4K @60, 7x 4K @30, 11x 1080p @60, 22x 1080p @30 (HEVC)
Camera	
GMSL	8 Fakra-Z connectors for GMSL 1/2 automotive cameras
I/O Interface	
USB	<ul style="list-style-type: none"> • 1 USB 3.2 Gen2 • 4 USB 3.1
Serial	2 COM RS-232/422/485
CAN Bus	2 Isolated CAN Bus support CAN FD
DIO	16 Isolated DIO (8 DI, 8 DO)
Button	<ul style="list-style-type: none"> • 1 Power Button • 1 Force Recovery Button • 1 Reset Button
Micro USB	<ul style="list-style-type: none"> • 1 Micro USB console debug port • 1 Micro USB OS flash port
SIM	2 SIM Card Socket
LED	Power, SSD, 2 User Programmable 2 OOB Status
Antenna	6 Antenna for 5G/WiFi/4G/LTE/GPRS/UMTS

Expansion	
PCIe	1 PCIe x16 slot with PCIe 3.0 x8 signal
M.2	<ul style="list-style-type: none"> • 1 M.2 Key B Socket (3042/3052, USB3) • 1 M.2 Key E Socket (2230, PCIe/USB2)
Storage	
SD	1 Micro SD Socket (External)
M.2	2 M.2 Key M Socket (2280, PCIe Gen3 x4)
eMMC	1 eMMC 5.1, 64GB
Power	
Power Input	DC 9V to 50V
Power Interface	3-pin Terminal Block : V+, V-, Frame Ground
Ignition Control	16-mode Software Ignition Control
Remote Switch	3-pin Remote Switch Terminal Block
Out-of-Band Management	
MCU	Nuvoton NUC980
Interface	OOB LAN, 10/100Mb Ethernet LAN, RJ45 Connector
Remote Management	Support Remote Power ON/OFF, Reset and Power Cycling
Management	
Dimensions	260 mm x 182 mm x 69 mm (10.24" x 7.17" x 2.72")
Weight	3.8 kg (8.39 lb)
Mounting	<ul style="list-style-type: none"> • Wallmount • DIN Rail and VESA Mount (Optional)
Environment	
Operating Temperature	30W TDP Mode : -25°C to 70°C (-13°F to 158°F) 40/50W TDP Mode : -25°C to 55°C (-13°F to 131°F)
Storage Temperature	-40°C to 85°C (-40°F to 185°F)
Humidity	5% to 95% Humidity, non-condensing
Relative Humidity	95% at 70°C
Shock	Operating, MIL-STD-810G, Method 516.7, Procedure I
Vibration	Operating, MIL-STD-810G, Method 514.6, Procedure I, Category 4
EMC	CE, FCC, EN50155, EN50121-3-2, EN62368-1

1.3.3 Specifications of EAC-5100

System	
Processor	NVIDIA® Jetson AGX Orin™ System-On-Module <ul style="list-style-type: none"> • 12-core Arm® Cortex®-A78AE v8.2 64-bit CPU • 2048-core NVIDIA Ampere™ architecture GPU with 64 Tensor Cores
Memory	R32 : 1 32GB LPDDR5 DRAM R64 : 1 64GB LPDDR5 DRAM
Storage	eMMC 5.1, 64 GB
Software Support	<ul style="list-style-type: none"> • Linux • NVIDIA JetPack SDK
Ethernet	
LAN 1 to LAN 2	10/100/1000 Base-T Ethernet GigE LAN, RJ45 Connector (Optional X-coded M12 Connector)
PoE	
LAN 3 to LAN 6	IEEE 802.3at (25.5W/48V) GigE PoE+ LAN, RJ45 Connector (Optional X-coded M12 Connector)
Graphics	
Interface	1 Digital Display, up to 4K60
Video Encode	<ul style="list-style-type: none"> • R32 : 1x 4K @60, 3x 4K @30, 6x 1080p @60, 12x 1080p @30 (HEVC) • R64 : 2x 4K @60, 4x 4K @30, 8x 1080p @60, 16x 1080p @30 (HEVC)
Video Decode	<ul style="list-style-type: none"> • R32 : 1x 8K @30, 2x 4K @60, 4x 4K @30, 9x 1080p @60, 18x 1080p @30 (HEVC) • R64 : 1x 8K @30, 3x 4K @60, 7x 4K @30, 11x 1080p @60, 22x 1080p @30 (HEVC)
I/O Interface	
USB	<ul style="list-style-type: none"> • 1 USB 3.2 Gen2 • 4 USB 3.1
Serial	2 COM RS-232/422/485
CAN Bus	2 Isolated CAN Bus support CAN FD
DIO	16 Isolated DIO (8 DI, 8 DO)
Button	<ul style="list-style-type: none"> • 1 Power Button • 1 Force Recovery Button • 1 Reset Button
Micro USB	<ul style="list-style-type: none"> • 1 Micro USB console debug port • 1 Micro USB OS flash port
SIM	2 SIM Card Socket
LED	Power, SSD, 2 User Programmable
Antenna	6 Antenna for 5G/WiFi/4G/LTE/GPRS/UMTS

Expansion	
PCIe	1 PCIe x16 slot with PCIe 3.0 x8 signal
M.2	<ul style="list-style-type: none"> • 1 M.2 Key B Socket (3042/3052, USB3) • 1 M.2 Key E Socket (2230, PCIe/USB)
Storage	
SD	1 Micro SD (External)
M.2	2 M.2 Key M Socket (2280, PCIe Gen3 x4)
eMMC	1 eMMC 5.1, 64GB
Power	
Power Input	DC 9V to 50V
Power Interface	3-pin Terminal Block : V+, V-, Frame Ground
Ignition Control	16-mode Software Ignition Control
Remote Switch	3-pin Remote Switch Terminal Block
Mechanical	
Dimensions	260 mm x 182 mm x 69 mm (10.24" x 7.17" x 2.72")
Weight	3.8 kg (8.39 lb)
Mounting	<ul style="list-style-type: none"> • Wallmount • DIN Rail and VESA Mount (Optional)
Environment	
Operating Temperature	30W TDP Mode : -25°C to 70°C (-13°F to 158°F) 40/50W TDP Mode : -25°C to 55°C (-13°F to 131°F)
Storage Temperature	-40°C to 85°C (-40°F to 185°F)
Humidity	5% to 95% Humidity, non-condensing
Relative Humidity	95% at 70°C
Shock	Operating, MIL-STD-810G, Method 516.7, Procedure I
Vibration	Operating, MIL-STD-810G, Method 514.6, Procedure I, Category 4
EMC	CE, FCC, EN50155, EN50121-3-2, EN62368-1

1.3.4 Specifications of EAC-5100-OOB

System	
Processor	NVIDIA® Jetson AGX Orin™ System-On-Module <ul style="list-style-type: none"> • 12-core Arm® Cortex®-A78AE v8.2 64-bit CPU • 2048-core NVIDIA Ampere™ architecture GPU with 64 Tensor Cores
Memory	R32 : 1 32GB LPDDR5 DRAM R64 : 1 64GB LPDDR5 DRAM
Storage	eMMC 5.1, 64 GB
Software Support	<ul style="list-style-type: none"> • Linux • NVIDIA JetPack SDK
Ethernet	
LAN 1 to LAN 2	10/100/1000 Base-T Ethernet GigE LAN, RJ45 Connector (Optional X-coded M12 Connector)
PoE	
LAN 3 to LAN 6	IEEE 802.3at (25.5W/48V) GigE PoE+ LAN, RJ45 Connector (Optional X-coded M12 Connector)
Graphics	
Interface	1 Digital Display, up to 4K60
Video Encode	<ul style="list-style-type: none"> • R32 : 1x 4K @60, 3x 4K @30, 6x 1080p @60, 12x 1080p @30 (HEVC) • R64 : 2x 4K @60, 4x 4K @30, 8x 1080p @60, 16x 1080p @30 (HEVC)
Video Decode	<ul style="list-style-type: none"> • R32 : 1x 8K @30, 2x 4K @60, 4x 4K @30, 9x 1080p @60, 18x 1080p @30 (HEVC) • R64 : 1x 8K @30, 3x 4K @60, 7x 4K @30, 11x 1080p @60, 22x 1080p @30 (HEVC)
I/O Interface	
USB	<ul style="list-style-type: none"> • 1 USB 3.2 Gen2 • 4 USB 3.1
Serial	2 COM RS-232/422/485
CAN Bus	2 Isolated CAN Bus support CAN FD
DIO	16 Isolated DIO (8 DI, 8 DO)
Button	<ul style="list-style-type: none"> • 1 Power Button • 1 Force Recovery Button • 1 Reset Button
Micro USB	<ul style="list-style-type: none"> • 1 Micro USB console debug port • 1 Micro USB OS flash port
SIM	2 SIM Card Socket
LED	Power, SSD, 2 User Programmable 2 OOB Status
Antenna	6 Antenna for 5G/WiFi/4G/LTE/GPRS/UMTS

Expansion	
PCIe	1 PCIe x16 slot with PCIe 3.0 x8 signal
M.2	<ul style="list-style-type: none"> • 1 M.2 Key B Socket (3042/3052, USB3) • 1 M.2 Key E Socket (2230, PCIe/USB)
Storage	
SD	1 Micro SD (External)
M.2	2 M.2 Key M Socket (2280, PCIe Gen3 x4)
eMMC	1 eMMC 5.1, 64GB
Power	
Power Input	DC 9V to 50V
Power Interface	3-pin Terminal Block : V+, V-, Frame Ground
Ignition Control	16-mode Software Ignition Control
Remote Switch	3-pin Remote Switch Terminal Block
Out-of-Band Management	
MCU	Nuvoton NUC980
Interface	OOB LAN, 10/100Mb Ethernet LAN, RJ45 Connector
Remote Management	Support Remote Power ON/OFF, Reset and Power Cycling
Management	
Dimensions	260 mm x 182 mm x 69 mm (10.24" x 7.17" x 2.72")
Weight	3.8 kg (8.39 lb)
Mounting	<ul style="list-style-type: none"> • Wallmount • DIN Rail and VESA Mount (Optional)
Environment	
Operating Temperature	30W TDP Mode : -25°C to 70°C (-13°F to 158°F) 40/50W TDP Mode : -25°C to 55°C (-13°F to 131°F)
Storage Temperature	-40°C to 85°C (-40°F to 185°F)
Humidity	5% to 95% Humidity, non-condensing
Relative Humidity	95% at 70°C
Shock	Operating, MIL-STD-810G, Method 516.7, Procedure I
Vibration	Operating, MIL-STD-810G, Method 514.6, Procedure I, Category 4
EMC	CE, FCC, EN50155, EN50121-3-2, EN62368-1

1.4 Mechanical Dimension

1.4.1 Dimensions of EAC-5000

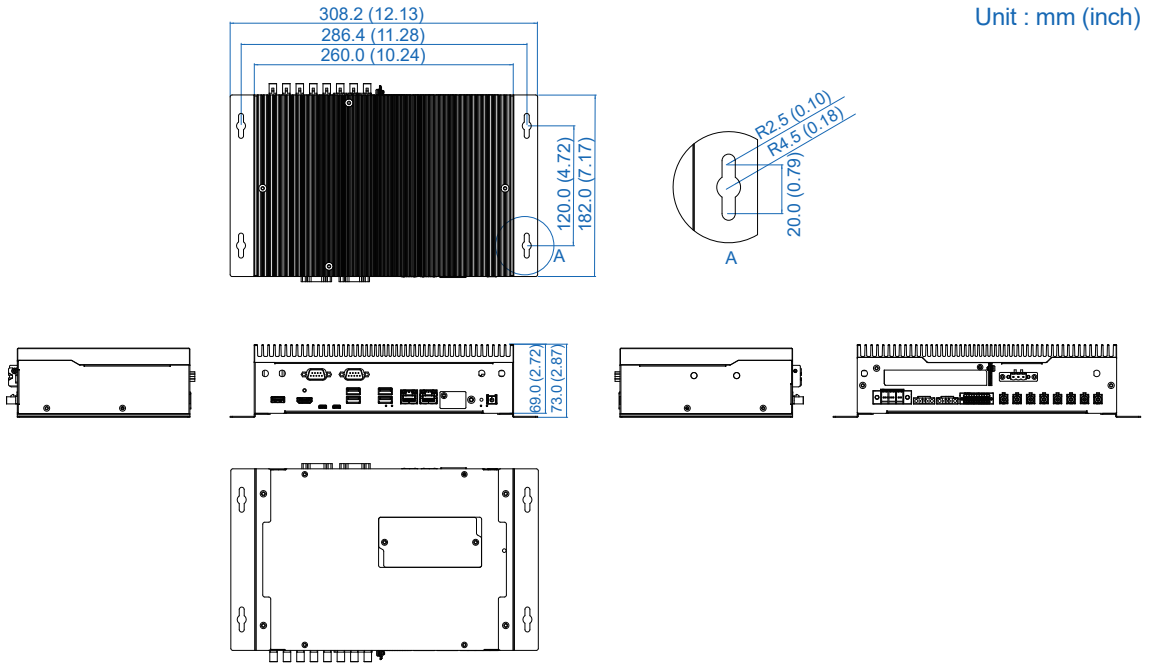

1.4.2 Dimensions of EAC-5000-OOB

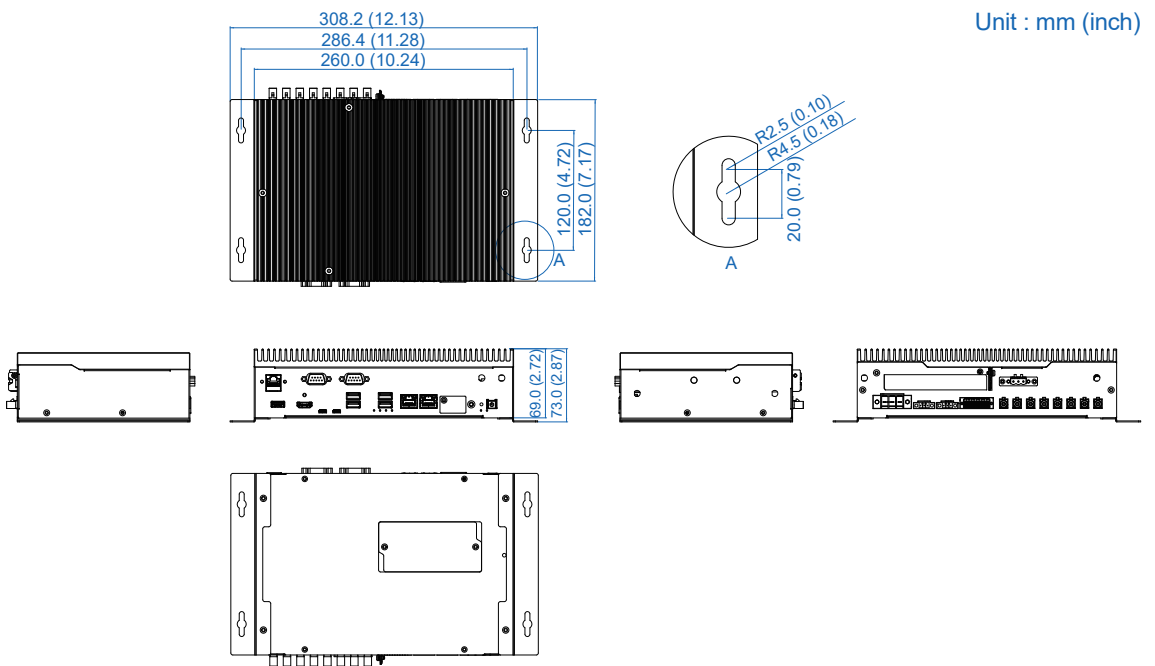

1.4.3 Dimensions of EAC-5100

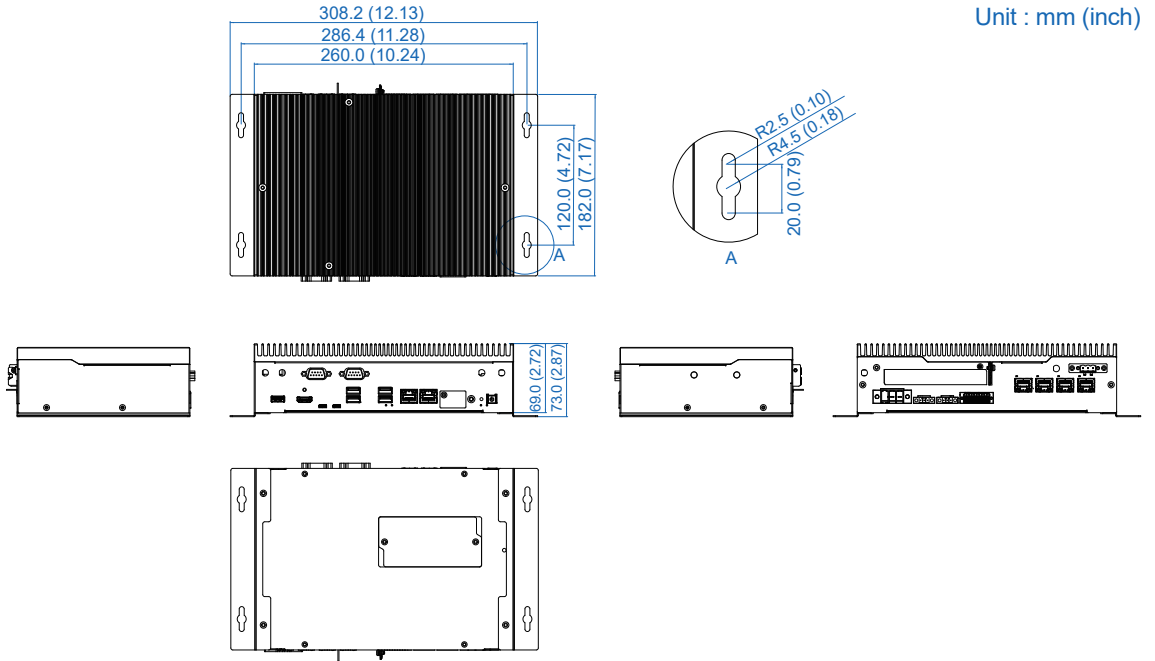

1.4.4 Dimensions of EAC-5100-OOB

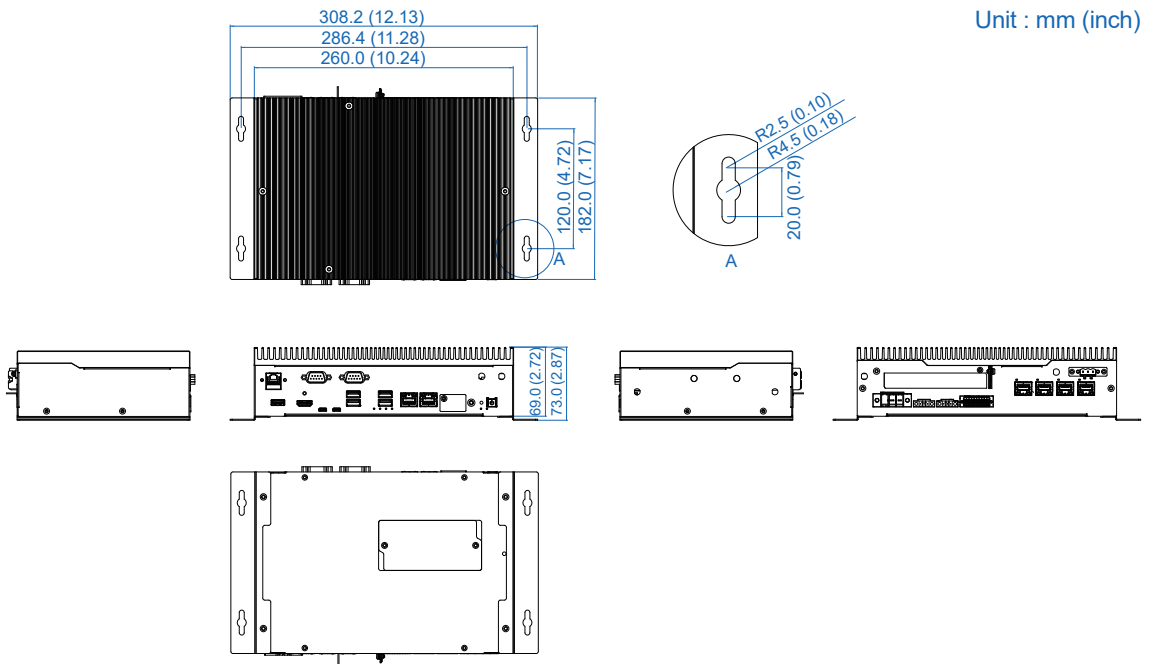







2

GETTING TO KNOW YOUR EAC-5000/EAC-5100

2.1 Packing List

Item	Description	Qty
1	EAC-5000/EAC-5100 Edge AI Computing System (According to the configuration of your order, EAC-5000/EAC-5100 series may contain micro SD and M.2 modules. Please verify these items if necessary.)	1

Item	Description	Outlook	Usage	P/N	Qty
1	Terminal block 3-pin (5.0mm)		IGN	51-2411R03-S1K	1
2	Terminal block 3-pin(7.62mm)		DC-IN	51-2611R03-S1N	1
3	Terminal block 3-pin(3.5mm)		CAN	51-2211R03-S1A	2
4	Terminal block 20-pin(2.54mm)		Isolated DIO	51-2112R20-S1D	1
5	PHILLIPS M3x4L, Ni+Ny		M.2 socket	53-2426204-80B	4
6	Flat #6-32x6L, Black+Ny		Fasten wall mount bracket to EAC-5000	53-I000350-311	4
7	Wall mount EAC-5000		Wall mount bracket	62-03P1164-0BA	2

2.2 Front Panel I/O & Functions

2.2.1 Functions of EAC-5000/5100 series

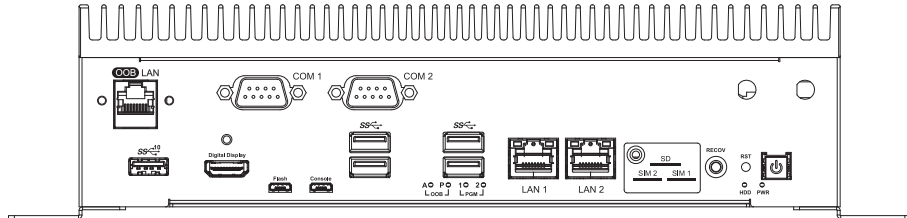

In Vecow EAC-5000 series, Most of the I/O connectors are located on the front panels. Most of the general connections to computer devices, such as COM, USB, LAN, Digital Display Port, Force Recovery button, Power Button, Reset Button, indicators are placed on the front panel.

2.2.1.1 Power Button

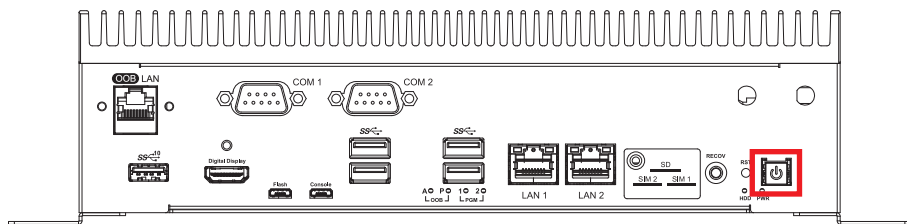

The Power Button is a non-latched switch with dual color LED indication.

To power on the system, press the power button and then the blue LED is lightened. To power off the system, you can either command shutdown by OS operation, or just simply press the power button.

LED Color	System Status
Solid Blue	System working
Solid Orange	System off with standby power

2.2.1.2 Reset Button

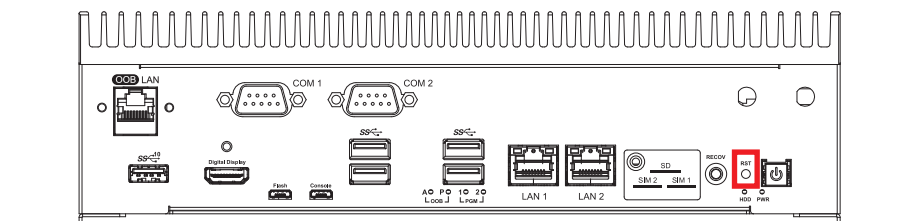

Used to force a full system reset.

2.2.1.3 Force_Recovery Button

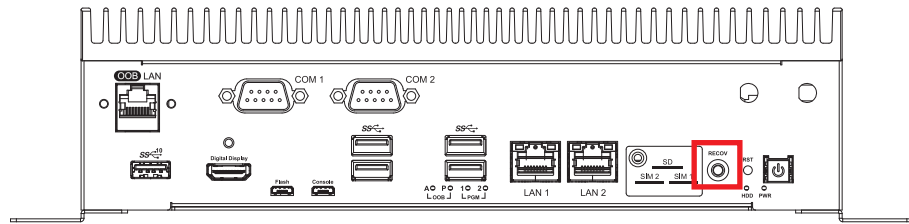

Used to enter Force Recovery Mode. Button is held down while either system is first powered on, or by pressing & releasing reset button while Recovery button is pressed.

2.2.1.4 Micro SD

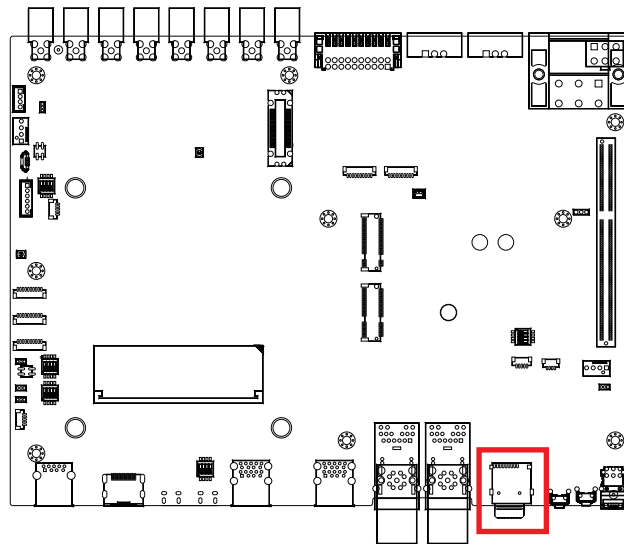
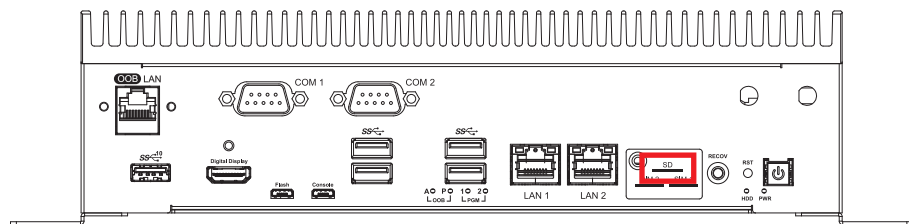

The external Micro SD card provides additional storage expansion. It is located behind the cover-plate on the front panel.

2.2.1.5 Two Nano SIM

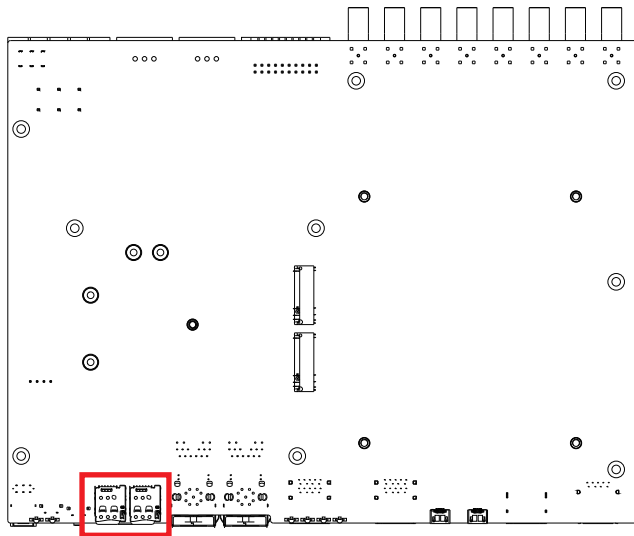
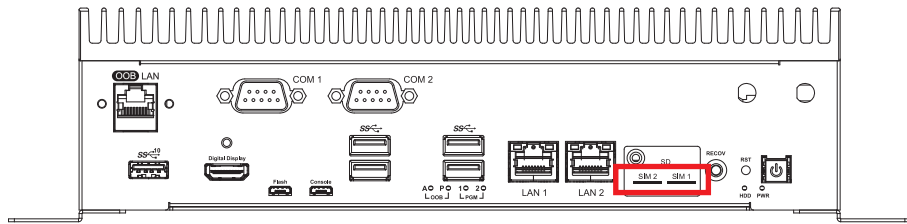

The external Nano SIM card offers wireless communication capability to the system.

2.2.1.6 Ethernet Port

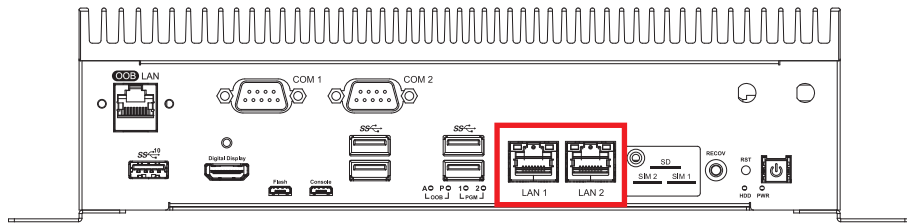

There are two 8-pin RJ-45 jacks supporting 10/100/1000 Mbps Ethernet connections on the front side of EAC-5000 series. It supports 1000BASE-T gigabit data signals over standard Ethernet Cat 5/Cat 6 cable.

LAN Chip	Function	Connector
RTL8211_LAN1	RJ-45(10/100/1000)	LAN1
I210_LAN2	RJ-45(10/100/1000)	LAN2

Using suitable RJ-45 cable, you can connect the system to a computer, or to any other devices with Ethernet connection, for example, a hub or a switch. The pin-outs of LAN1 and LAN2 are listed as follows:

Pin No.	10/100 Mbps	1000Mbps
1	E_TX+	MDI0_P
2	E_TX-	MDI0_N
3	E_RX+	MDI1_P
4	-----	MDI2_P
5	-----	MDI2_N
6	E_RX-	MDI1_N
7	-----	MDI3_P
8	-----	MDI3_N

Each LAN port is supported by standard RJ-45 connector with LED indicators to present Active/ Link/ Speed status of the connection .

LED Location	LED Color	10Mbps	100Mbps	1000Mbps
Right	Green/ Orange	Off	Solid Green	Solid Orange
Left	Yellow	Twinkling Yellow	Twinkling Yellow	Twinkling Yellow

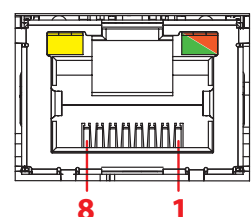

2.2.1.7 USB 3.2 Gen1

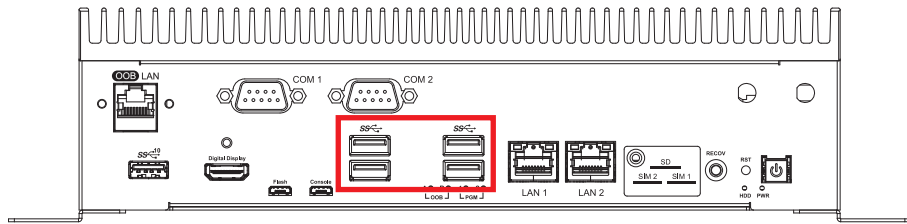

There are 4 USB 3.2 Gen1 connections available supporting up to 5Gb per second data rate in the front panel of EAC-5000 series. It is also compliant with the requirements of Super Speed (SS), High Speed (HS), Full Speed (FS) and Low Speed (LS).

2.2.1.8 Digital Display Port

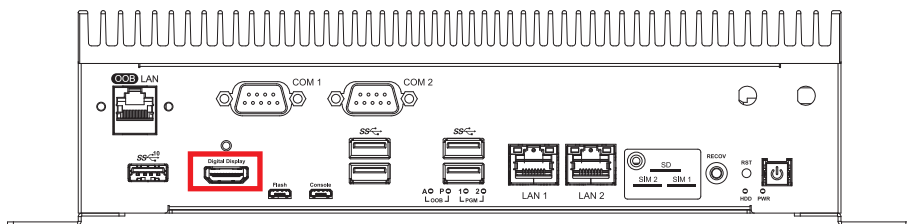

Onboard HDMI Ports support HDMI V2.1 interface, connection supports up to Up to 3840 x 2160 @60Hz.

2.2.1.9 USB 3.2 Gen2

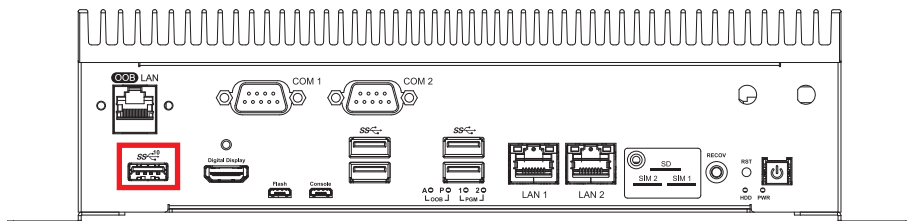

This USB 3.2 connections available supporting up to 10Gb per second data rate in the front side of EAC-5000 series. It also compliant with the requirements of Super Speed (SS), high speed (HS), full speed (FS) and low speed (LS).

2.2.1.10 COM Port

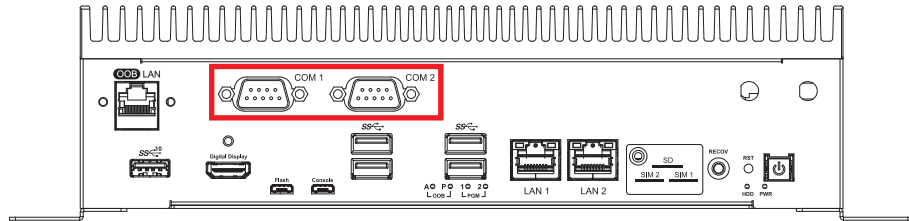

COM 1,2 can be configured for RS-232, RS-422, or RS-485 with auto flow control communication. The default definition of COM 1 and COM2 is RS-232; but if you want to change to RS-422 or RS-485, you can find the setting in software.

The rear D-SUB connector pin assignments are listed in the following table :

Serial Port	Pin No.	RS-232	RS-422 (5-wire)	RS-485 (3-wire)
COM1 COM2	1	-----	TXD-	DATA-
	2	RXD	TXD+	DATA+
	3	TXD	RXD+	-----
	4	-----	RXD-	-----
	5	GND	GND	GND
	6	-----	-----	-----
	7	RTS	-----	-----
	8	CTS	-----	-----
	9	-----	-----	-----

2.2.1.11 Console Port

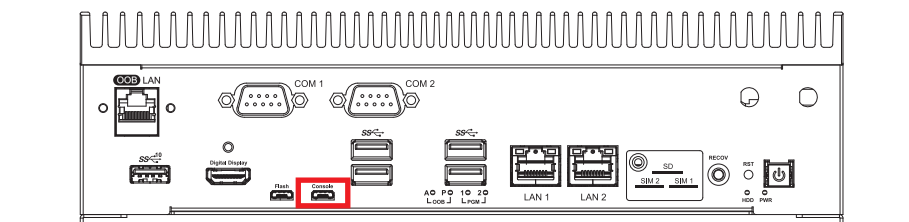

System debug Port, Micro USB to UART that connects to the SOM serial console.

Pin No.	Function
1	+V5
2	USB_DATA-
3	USB_DATA+
4	NC
5	GND

2.2.1.12 Flash Port

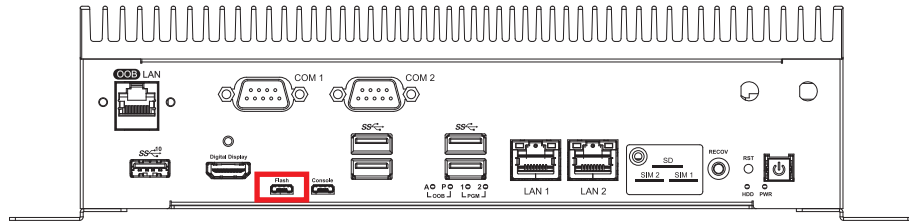

The EAC-5000 USB Recovery mode provides an alternate boot device (USB). In this mode, the system is connected to a host system and boots over USB. This is used when a new image needs to be flashed. USB0 must be available to use as USB Device for USB Recovery Mode.

Pin No.	Function
1	VBUS_DET
2	USB_DATA-
3	USB_DATA+
4	NC
5	GND

2.2.1.13 PWR & Status LED Indicators

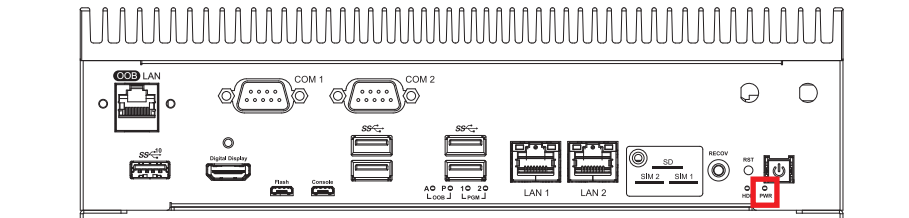

LED Color	System Status
Green (PWR LED)	+5V Power Ready

2.2.1.14 HDD & Status LED Indicators

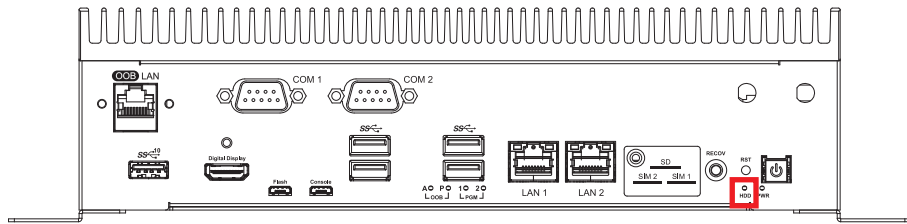

Orange-HDD LED : A SSD Storage LED. If the LED is on, it indicates that the system's storage is functional. If it is off, it indicates that the system's storage is not functional. If it is flashing, it indicates data access activities are in progress.

2.2.1.15 Two user Programmable LEDs

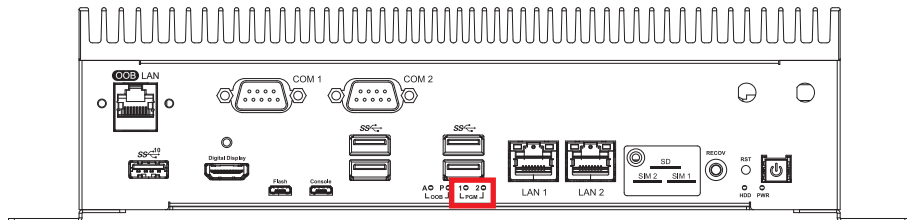

There are two Programmable LEDs, user can define the state of the led by himself.

2.2.1.16 OOB states LED indicator (EAC-5000-OOB/EAC-5100-OOB)

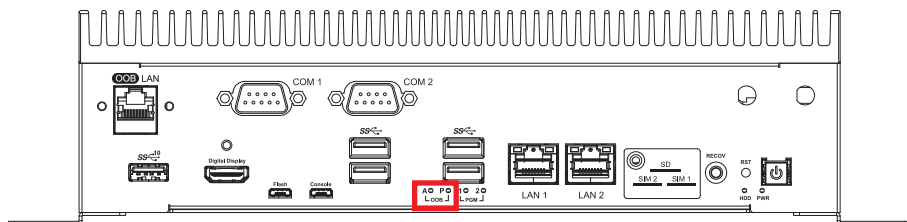

The LED indicator can instantly judge the power status of OOB Enabler and the connection status of OOB Enabler and Allxon Portal. If both LEDs are on, it means OOB Enabler is running and the connection to Allxon Cloud is stable.

2.2.1.17 OOB LAN Connector

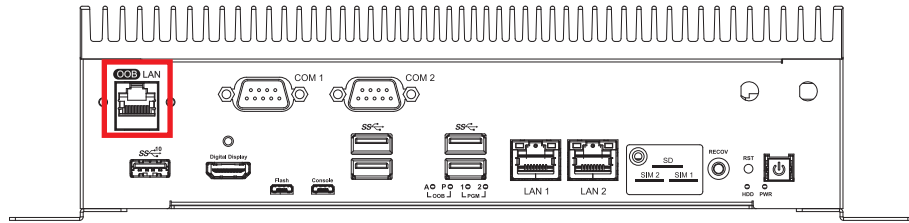

There are 8-pin RJ-45 port supporting 10/100 Mbps Ethernet connections in the EAC-5000-OOB.

The pin assignment of for OOB is listed in the following table:

Pin No.	Function
1	E_TX+
2	E_TX-
3	E_RX+
4	----
5	----
6	E_RX-
7	----
8	----

The LAN port is supported by a standard RJ-45 connector with LED indicators to present active/link/speed status of the connection.

The LED indicator below the USB port lightens in solid yellow when the cable is properly connected to a 10/100Mbps Ethernet network;

The left LED will keep twinkling/off when 100Mbps Ethernet data packets are being transmitted/received.

LED Location	LED Color	10Mbps	100Mbps
Left	Green	None	Twinkling Green
Right	Yellow	Solid Yellow	Solid Yellow

2.2.1.18 LED Function description

Part location	Definition
LED_ETH	LED indicator for OOB network connection condition.
LED_PWR	LED indicator for OOB power status.

More detail LED indications are listed as follows:

LED_PWR	LED_ETH	Status
Blinking	Blinking	<ul style="list-style-type: none"> • OOB Enabler is power on but not connected to internet • System reset • Updating firmware
Solid Orange	Blinking	<ul style="list-style-type: none"> • OOB Enabler is power on and trying to launch Allxon Agent • Watchdog has launched Allxon Agent and Allxon Octo (plugin) • An error occurred when connecting plugin to Allxon Agent
Solid Orange	Solid Orange	OOB Enabler is powered on and connected to Allxon Portal for Allxon services

2.3 Rear Panel I/O & Functions

2.3.1 Functions of EAC-5000

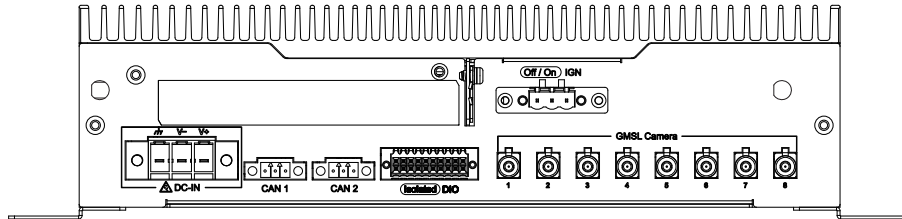

In Vecow EAC-5000 series, Some of the I/O connectors are located on the rear panels. Such as GMSL Camera, CAN Port, Power input, DIO Port indicators are placed on the rear panel.

2.3.1.1 Power Terminal Block

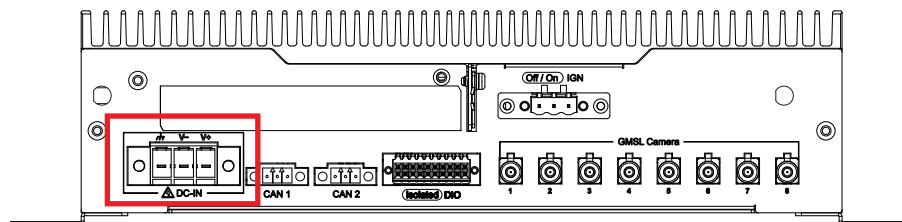

EAC-5000 series supports 9V to 50V DC wide range power input by terminal block in the rear side.

And the pin define is as below table.

Pin No.	Definition
1	Chassis Ground
2	V-
3	V+

2.3.1.2 CAN Port

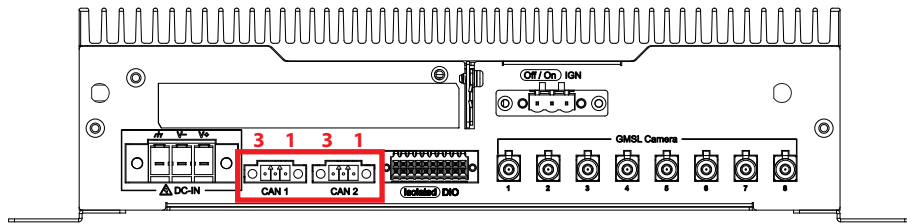

CAN1/CAN2 Bus Connector Pin Out:

Pin No.	Function
1	CAN_H
2	CAN_L
3	GND

2.3.1.3 Isolated DIO Port

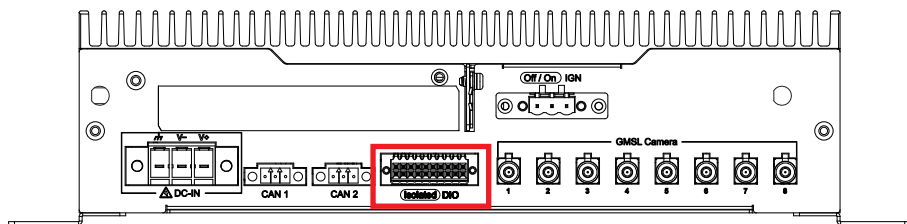

There is a 16-bit (8-bit DI, 8-bit DO) connectors in the rear side. DI/DO support NPN (sink) and PNP (Source) mode, Each DI channel is equipped with a photocoupler for isolated protection. Each DO with isolator chip, Config by a Jumper for each DIO connector. DO Safety-Related Certifications:

- 4242-VPK Basic Isolation per DIN V VDE V 0884-10 and DIN EN 61010-1
- 3-KVRMS Isolation for 1 minute per UL 1577
- CSA Component Acceptance Notice 5A, IEC 60950-1 and IEC 61010-1 End Equipment Standards
- GB4943.1-2011 CQC Certified

Pin No.	Definition	Function	Pin No.	Definition	Function
1	EXT_IN0	GPIO04	11	EXT_OUT0	GPIO25
2	EXT_IN1	GPIO11	12	EXT_OUT1	GPIO28
3	EXT_IN2	GPIO12	13	EXT_OUT2	GPIO31
4	EXT_IN3	GPIO14	14	EXT_OUT3	GPIO36

5	EXT_IN4	GPIO18	15	EXT_OUT4	GPIO41
6	EXT_IN5	GPIO19	16	EXT_OUT5	GPIO42
7	EXT_IN6	GPIO23	17	EXT_OUT6	GPIO43
8	EXT_IN7	GPIO24	18	EXT_OUT7	GPIO44
9	+VDI_COM	--	19	GND	--
10	GND	--	20	+VDIO_EXT	--

Notice: +VDIO_EXT is external 6-40VDC (NPN) or external 6-48VDC(PNP).

DI reference circuit :

Sink Mode
(NPN)

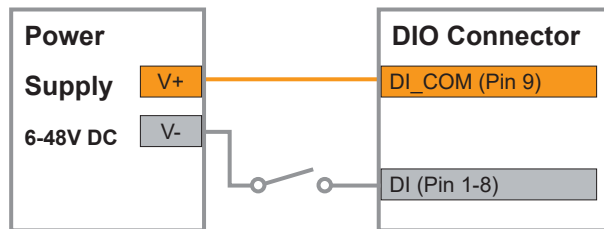

Source Mode
(PNP)

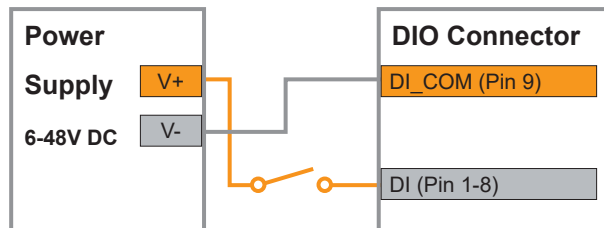

DO reference circuit :

Sink Mode (NPN, Default)

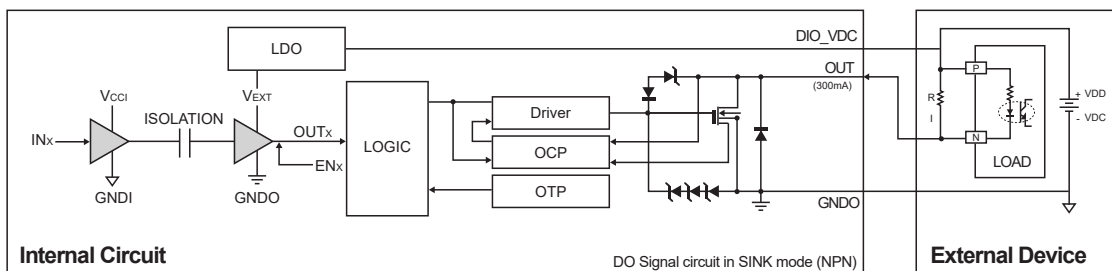

Source (PNP)

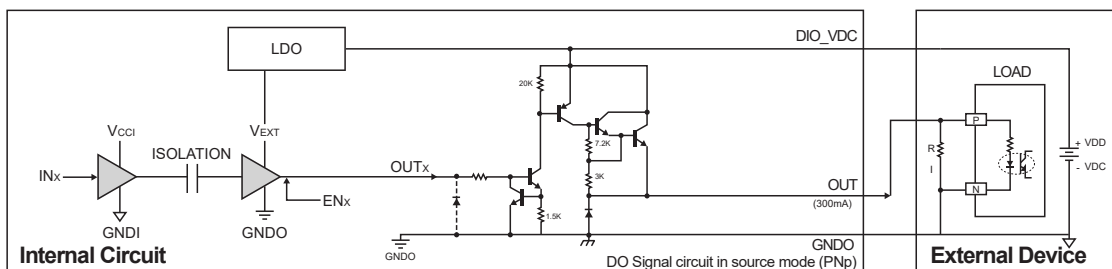

2.3.1.4 GMSL Camera Port

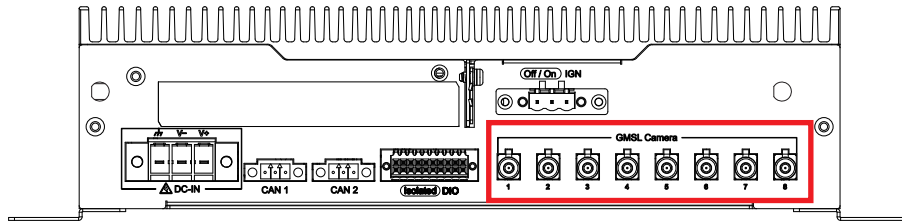

There are eight FAKRA connectors in the rear side of EAC-5000. Each camera connects to the EAC-5000 through a single coax cable. Using GMSL2 (Gigabit Multimedia Serial Link) connections, the cameras are connected to a two-port deserializer. The output of the deserializer is MIPI CSI-2.

2.3.1.5 Remote Power On/Off Switch & Ignition

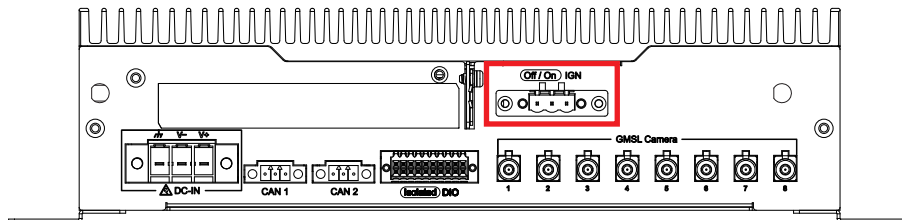

It is a 3-pin power-on or power-off switch through terminal block. You could turn on or off the system power by using this contact. This terminal block supports dual function of soft power-on/power-off (instant off or delay 4 second).

Pin No.	Definition
1	Ignition(IGN)
2	SW+
3	SW-

2.3.2 Functions of EAC-5100

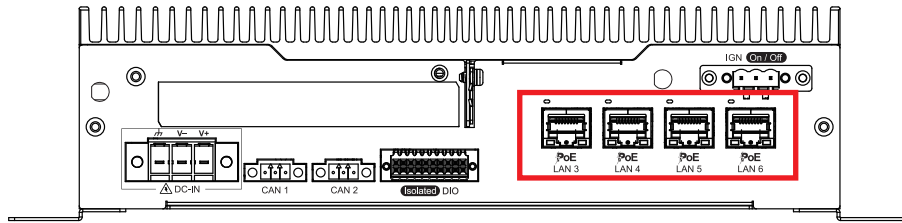

LAN3~LAN6: PoE Ports

There are 4 RJ45 connectors in the front side of EAC-5100. It supports IEEE 802.3at (PoE+) Power over Ethernet (PoE) connection delivering up to 25W/54V per port and 1000BASE-T gigabit data signals over standard Ethernet Cat 5/Cat 6 cable.

Each PoE connection is powered by Intel® I350 Gigabit Ethernet controller and independent PCI express interface to connect with multi-core processor for network and data transmit optimization. Only when PoE port starts to supply power to power devices, the dedicated LED will be lightened.

PS. Suggest to use PoE function when power input is over 24V.

The pin-outs of LAN 3~LAN 6 are listed as follows :

Pin No.	10/100 Mbps	1000Mbps	PoE
1	E_TX+	MDI0_P	PoE+
2	E_TX-	MDI0_N	PoE+
3	E_RX+	MDI1_P	PoE-
4	-----	MDI2_P	-----
5	-----	MDI2_N	-----
6	E_RX-	MDI1_N	PoE-
7	-----	MDI3_P	-----
8	-----	MDI3_N	-----

Each LAN port is supported by standard RJ-45 connector with LED indicators to present Active/Link/Speed status of the connection.

The LED indicator on the right bottom corner lightens in solid green when the cable is properly connected to a 100Mbps Ethernet network; The LED indicator on the right bottom corner lightens in solid orange when the cable is properly connected to a 1000Mbps Ethernet network; The left LED will keep twinkling/off when Ethernet data packets are being transmitted/received.

LED Location	LED Color	10Mbps	100Mbps	1000Mbps
Right	Green/ Orange	Off	Solid Green	Solid Orange
Left	Orange	Twinkling Orange	Twinkling Orange	Twinkling Orange

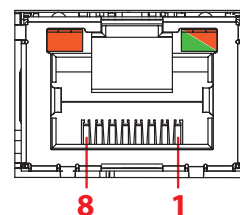

2.4 Main Board Connector & Jumper Locations

2.4.1 TOP View of MB

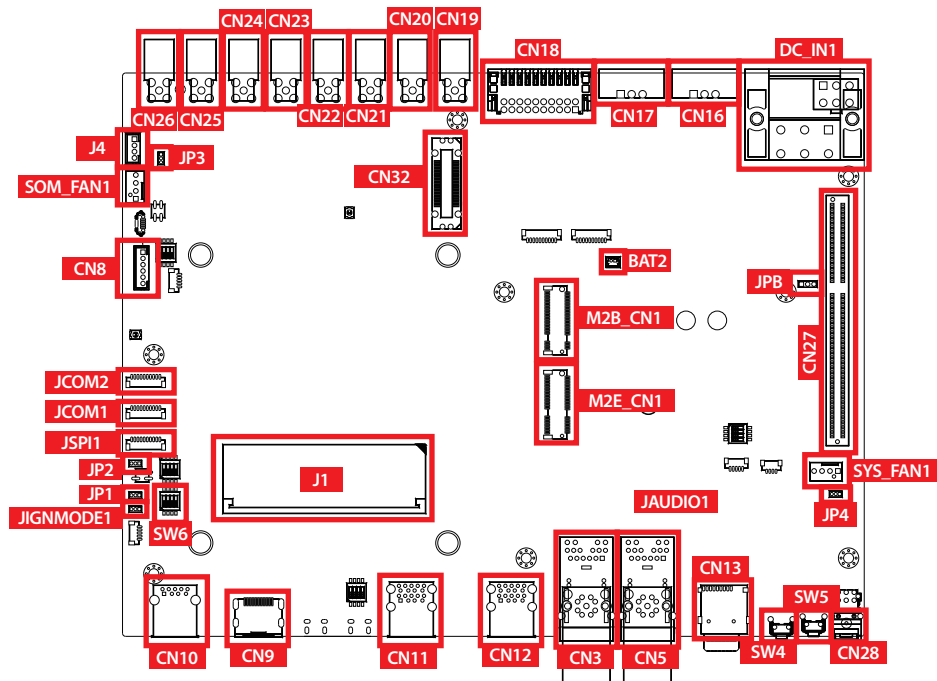

BOT View of MB

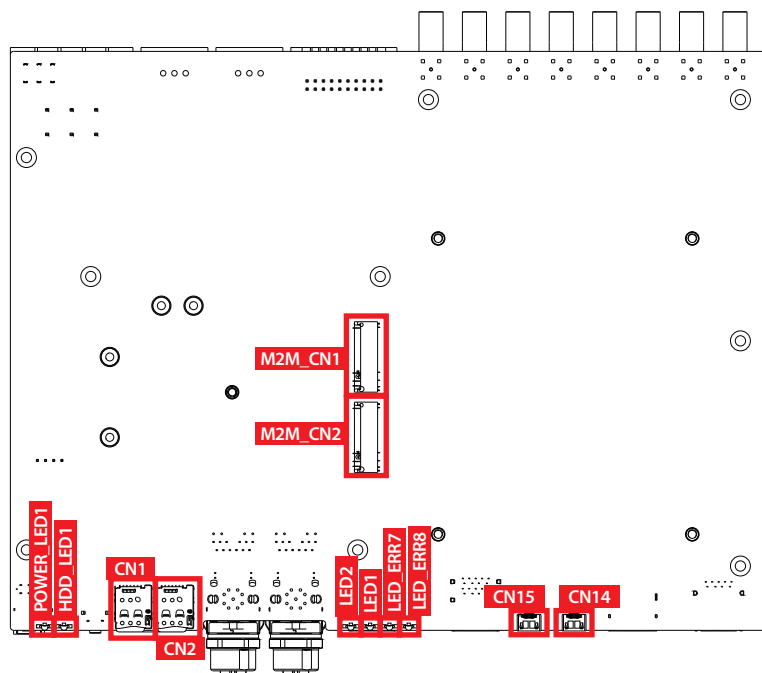

2.4.1.1 CN32 Board to Board Connector to PoE LAN Board (PCIe x4)

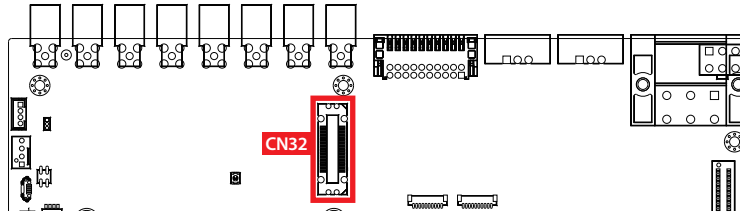

CN32 connector only apply to EAC-5000-PE board use. Host I/Fs supported PCIe x4 transfer 4 GigE with PoE LAN.

2.4.1.2 J4 IGNITION Control and Remote Power on switch

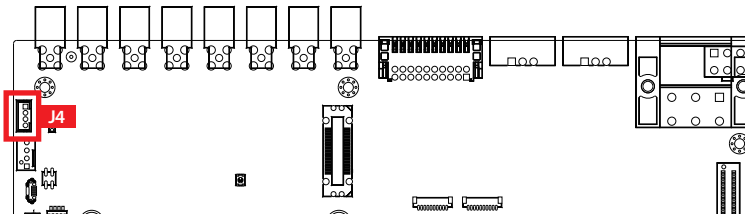

Pin assignment as the following table :

	Pin No.	Signal Name
	1	FP_PWR_BTN_P
	2	GND
	3	IGNITION
	4	GND

2.4.1.3 Fan Connector (SOM_FAN1)

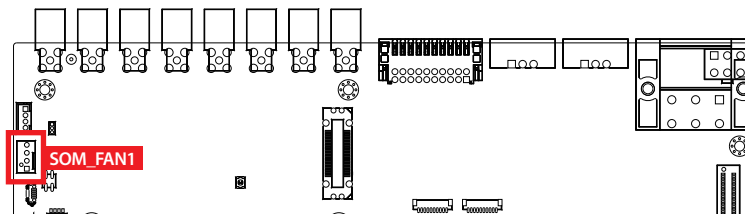

Pin No.	Description	Pin No.	Description
1	GND	2	+12V (1A max)
3	Fan Speed Sencor	4	Fan PWM

2.4.1.4 CN8 : 10/100 Mb LAN Connector for OOB (EAC-5X00-OOB)

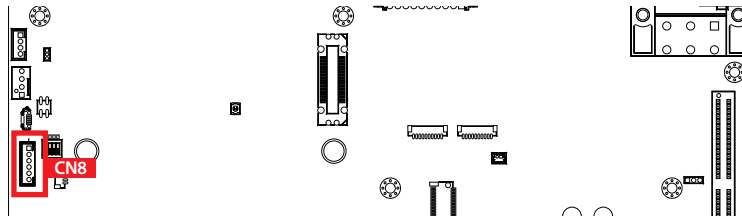

	Pin No.	Definition
	1	TX+_RJ1
	2	TX-_RJ2
	3	RX+_RJ3
	4	RX-_RJ6
	5	GND_EARTH
6	GND_EARTH	

2.4.1.5 JCOM1/JCOM2 : COM Serial Port

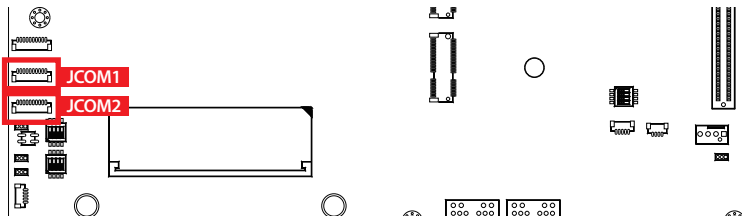

Serial port 1/2 (JCOM 1,2) can be configured for RS-232, RS-422, or RS-485 with auto flow control communication. The default definition of COM 1 ,2 is RS-232, if you want to change to RS-422 or RS-485, you must change by software setting.

	Pin No.	RS-232	RS-422 (5-wire)	RS-485 (3-wire)
	1	-----	-----	-----
	2	GND	GND	GND
	3	-----	-----	-----
	4	-----	RXD-	-----
	5	CTS	-----	-----
	6	TXD	RXD+	-----
	7	RTS	-----	-----
	8	RXD	TXD+	DATA+
	9	-----	-----	-----
10	-----	TXD-	DATA-	

2.4.1.6 JSPI1 : SPI Connector

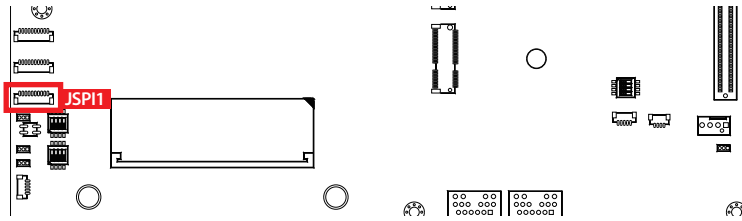

	Pin No.	Definition
	1	P3.3V
	2	GND
	3	SPI1_MOSI_LS
	4	SPI1_MISO_LS
	5	SPI1_CS0_LS
	6	SPI1_SCK_LS
	7	SPI1_CS1_LS
	8	I2C4_SDA
	9	-----
10	I2C4_SCL	

2.4.1.7 J1 : Jetson AGX Orin SOM Socket

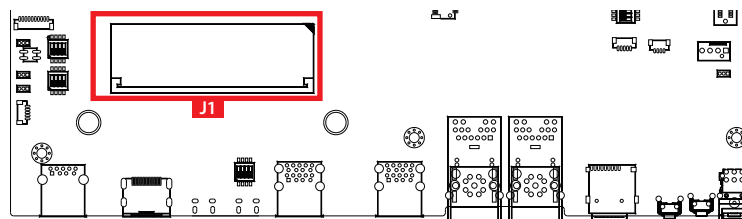

Connection to Jetson AGX Orin SOM.

2.4.1.8 BAT2 : RTC Battery Connector.

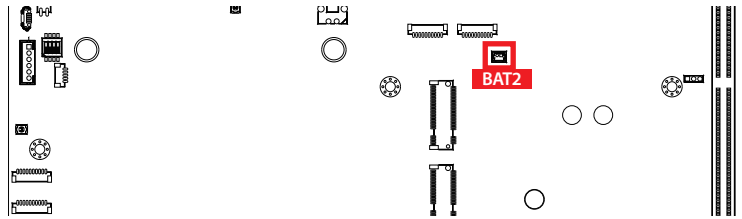

The system's real-time clock is powered by a Manganese Dioxide Lithium Battery. It is Equipped with Panasonic CR2032 battery. It is recommended that you not replace the RTC battery on your own. If the RTC battery needs to be changed, please contact the Vecow RMA service team.

2.4.1.9 M2B_CN1 : M.2 key B Slot for USB2.0,USB3.2 Gen1 support

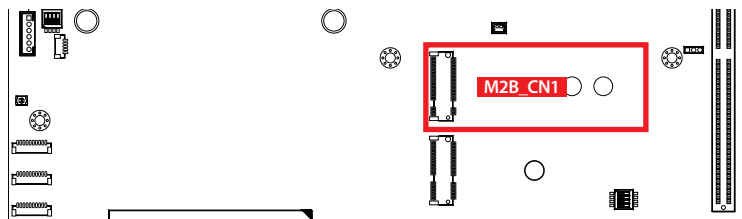

M.2 key B connector is suitable for applications that use Host I/Fs supported USB 3.0, USB 2.0, I2C , like wireless connectivity including LTE/5G, NVMe Module card types include 3042/3052.

2.4.1.10 M2E_CN1 : M.2 key E Slot for USB 2.0, PCIe Gen3x1 support

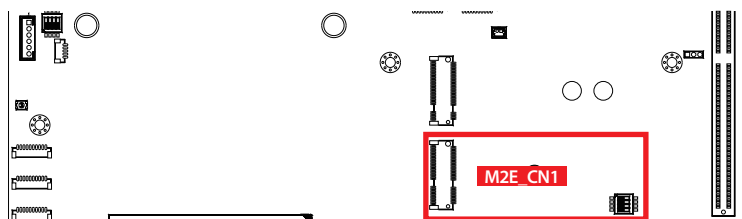

M.2 key E connector is suitable for applications that use wireless connectivity including Wi-Fi, Bluetooth, NFC or GNSS. Module card types include 2230.

2.4.1.11 JAUDIO1 : Headphone Out and Microphone In Connector

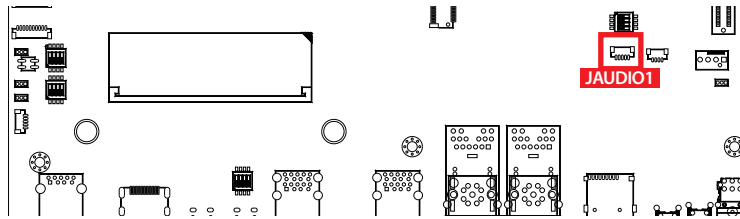

	Pin No.	Definition
	1	HPOUT_L
	2	HPOUT_R
	3	GND
	4	MIC_L
	5	MIC_R

2.4.1.12 SYS_FAN1 : System FAN Connector

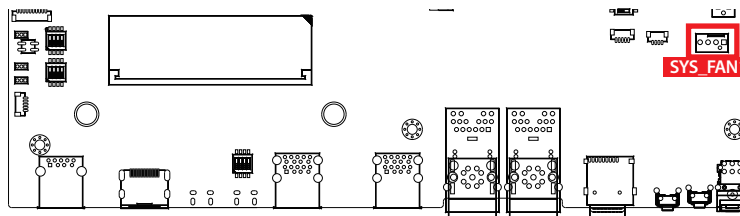

	Pin No.	Definition
	1	GND
	2	+12V (1.0A max)
	3	-----
	4	Fan PWM

2.4.1.13 CN27 : PEG Connector

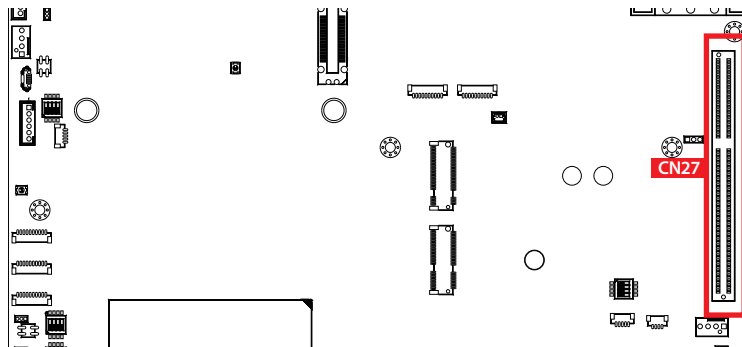

2.4.1.14 M2M_CN1/ M2M_CN2 : PCIe Gen3 x4 support

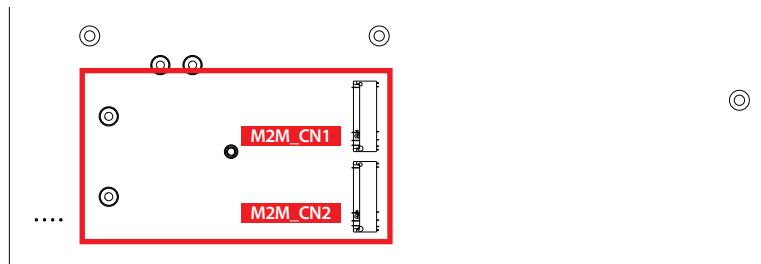

M.2 key M connector is suitable for applications that use Host I/Fs supported PCIe x4, like w NVME Module card types include 2280.

2.5 Main Board Jumper Settings

2.5.1.1 Board Top View of EAC-5000 Main Board with Jumper.

The figure below is the top view of EAC-5000 series main board which is the main board. It shows the location of the jumpers.

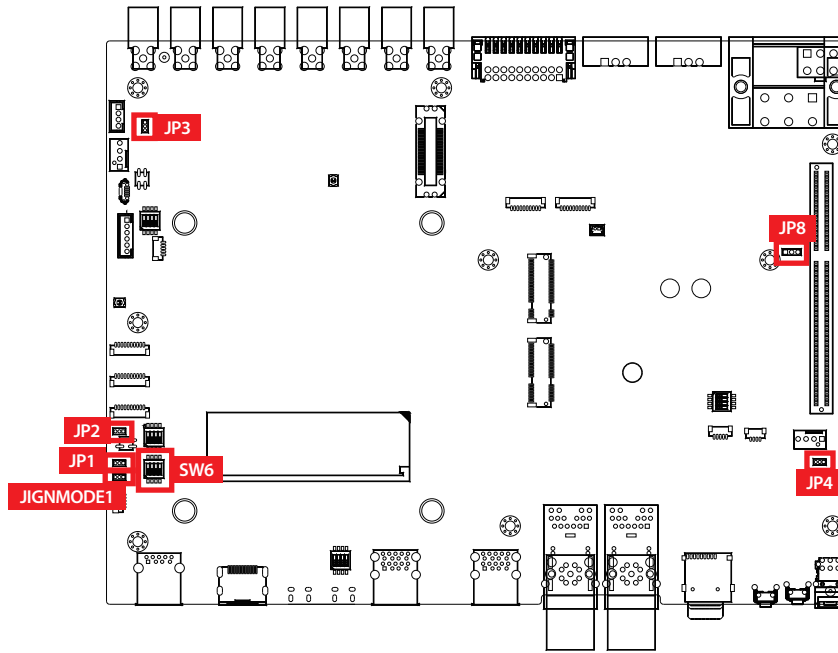

You may configure your card to match the needs of your application by setting jumpers. A jumper is a metal bridge used to close an electric circuit. It consists of two metal pins and a small metal clip (often protected by a plastic cover) that slides over the pins to connect them. To "close" a jumper, you connect the pins with the clip. To "open" a jumper, you remove the clip. Sometimes a jumper will have three pins, labeled 1, 2 and 3. In this case you would connect either pins 1 and 2, or 2 and 3.

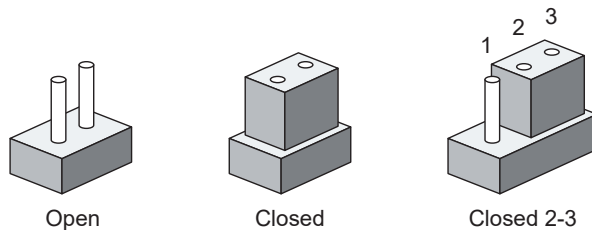

You may configure your card to match the needs of your application by DIP switch. As below show the DIP switch on and off.

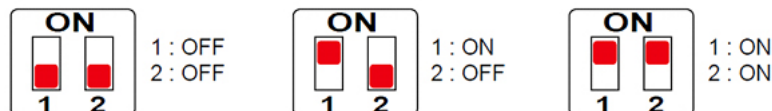

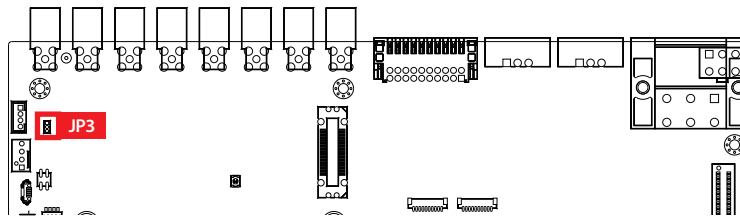

2.5.1.2 JP3 : SOM_FAN1 Operation Voltage Select

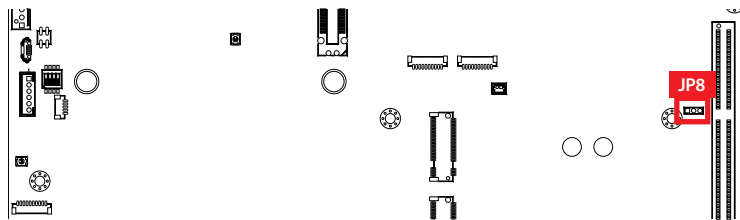

	Pin No.	Definition
	1-2	FAN Operation Voltage 5V
	2-3	FAN Operation Voltage 12V(Default)

2.5.1.3 JP8: PoE Power On Select Mode



	Pin No.	Definition
	1-2	POE Power On by P3.3V_SB (Default)
	2-3	POE Power On on by P3.3V

2.5.1.4 JP2 : COM2 RS485 Terminal resistance ON/OFF

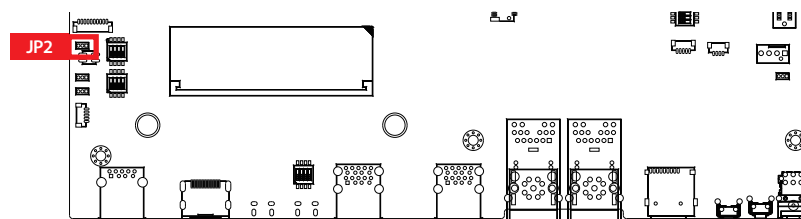

2.5.1.5 JP1 : COM1 RS485 Mode Terminal resistance ON/OFF

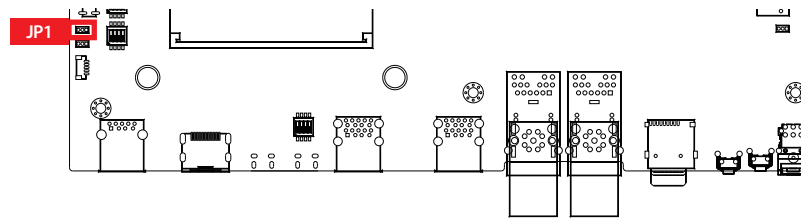

There are two Pin Header JP1 and JP2 to set terminal resistor (120Ω) ON/OFF of COM RS485 mode function.

Jumper	Pin No.	Definition
JP1(COM1)	1-2	RS485 Mode Terminal resistance OFF (Default)
JP2(COM1)	2-3	RS485 Mode Terminal resistance ON

2.5.1.6 JIGNMODE1 : Ignition Mode Select

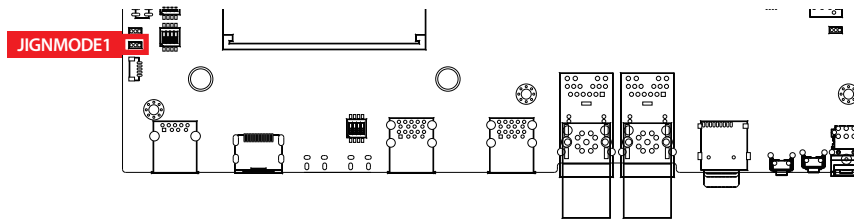

	Pin No.	Definition
	1-2	H/W MODE(Default)
	2-3	S/W MODE

2.5.1.7 JP4 : SYS_FAN1 Operation Voltage Select

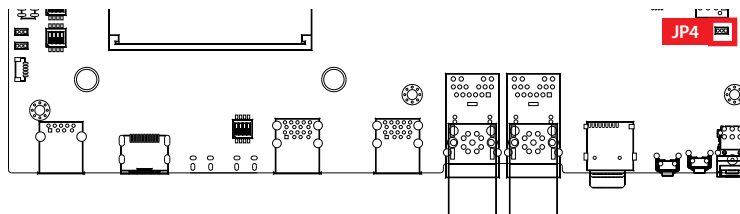

	Pin No.	Definition
	1-2	FAN Operation Voltage 5V
	2-3	FAN Operation Voltage 12V(Default)

2.6 Ignition Control

EAC-5000 series provides ignition power control feature for in-vehicle applications. The built-in MCU monitors the ignition signal and turns on/off the system according to pre-defined on/off delay period.

2.6.1 Adjust Ignition Control Modes





EAC-5000 series provides 16 modes of different power on/off delay periods adjustable via SW6 switch. The default DIP switch is set to 0 in ATX power mode.

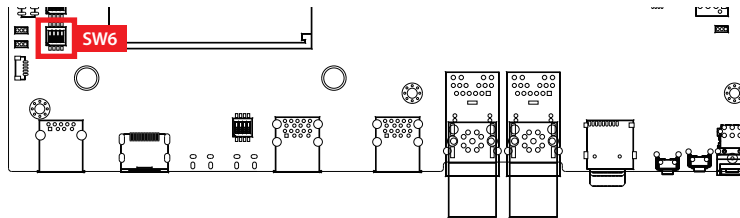



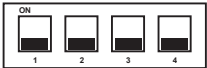
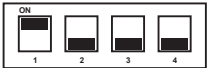
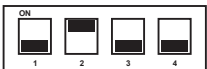
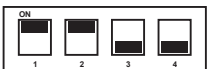

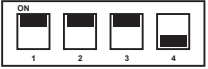

When using the OOB function, the Ignition control function cannot be used at the same time.

SW6 : Ignition Control



The modes are listed in below table :

DIP Switch Position	Power on delay	Power off delay	Switch Position
0	ATX mode		
1	No delay	10 seconds	
2	No delay	15 seconds	
3	No delay	20 seconds	
4	No delay	30 seconds	
5	No delay	60 seconds	
6	5 seconds	10 seconds	

7	5 seconds	30 seconds	
8	5 seconds	60 seconds	
9	5 seconds	90 seconds	
A	5 seconds	120 seconds	
B	10 seconds	10 seconds	
C	10 seconds	30 seconds	
D	10 seconds	60 seconds	
E	10 seconds	90 seconds	
F	AT Mode		

2.6.2 Ignition Control Wiring

To activate ignition control, you need to provide IGN signal via the 3-pin pluggable terminal block locates in the back panel. Please find below the general wiring configuration.

Pin No.	Definition
1	Ignition (IGN)
2	SW+
3	SW-



For testing purpose, you can refer to the picture blow to simulate ignition signal input controlled by a latching switch.

3

SYSTEM SETUP

3.1 How to Open Your EAC-5000/EAC-5100

Step 1 Remove four I-M3x6L screws.

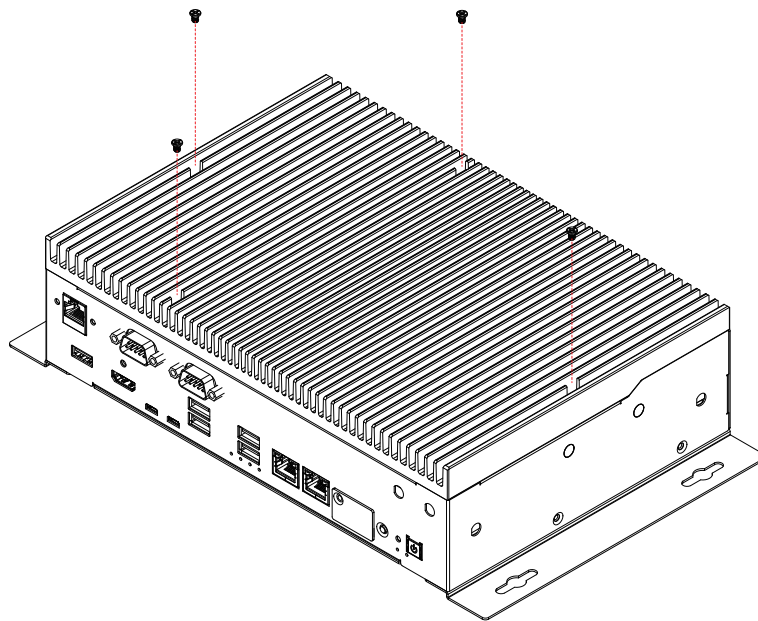

Step 2 Pick up Heat Sink.

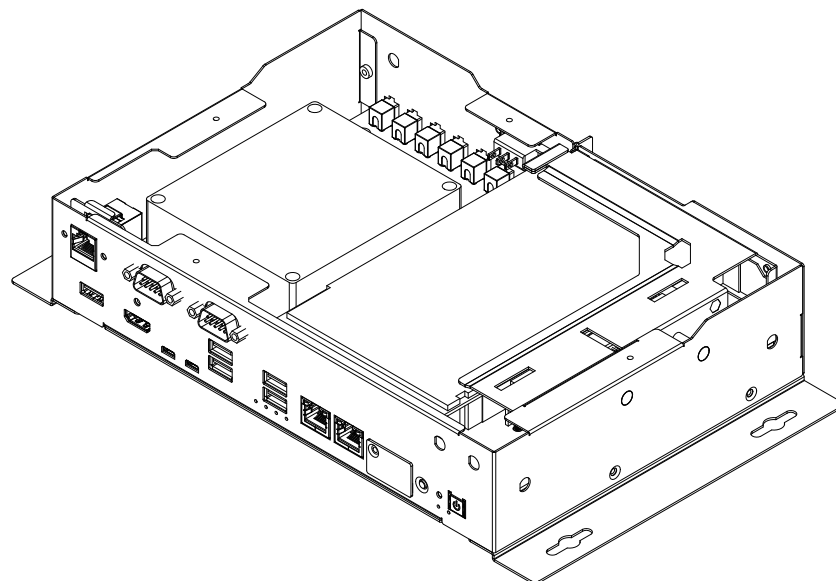

3.2 Installing Nano SIM Card

Step 1 Remove one F-M3x4L screw on SD/SIM cover.

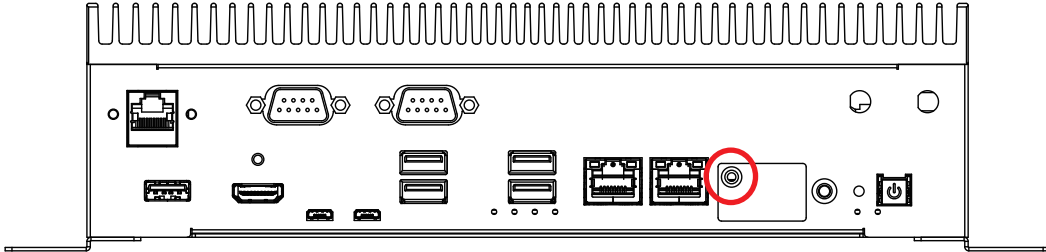

Step 2 Inserting SIM card, make sure the system power is not plugged.

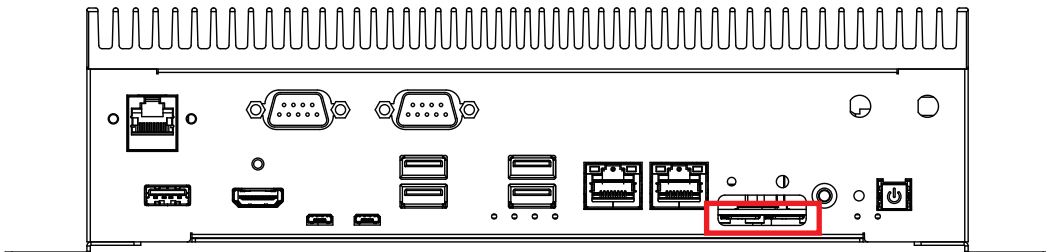

3.3 Installing Micro SD Card

Step 1 Remove one F-M3x4L screw on SD/SIM cover.

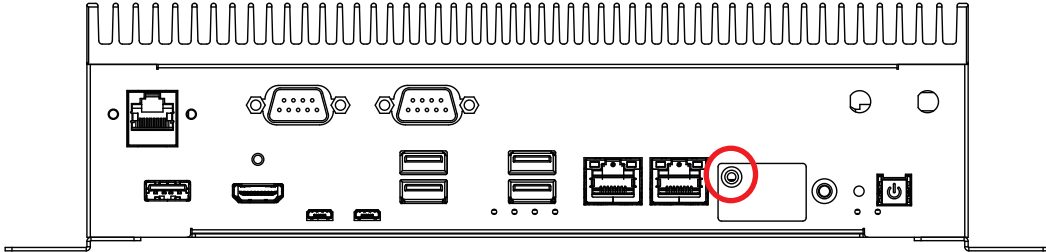

Step 2 Inserting SD card.

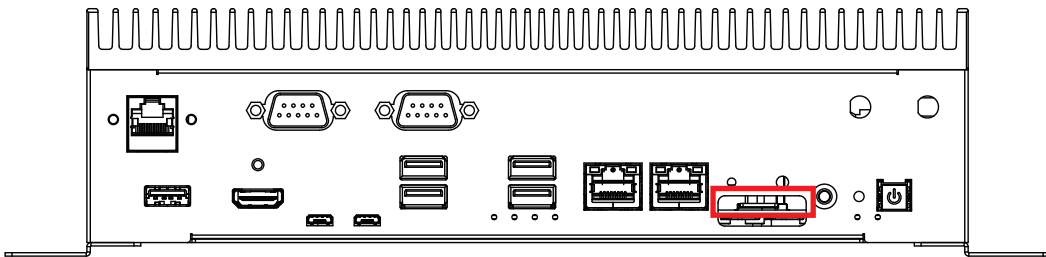

3.4 Installing PCIe Card

Step 1 Remove two F-M3x4L screws on rear panel.

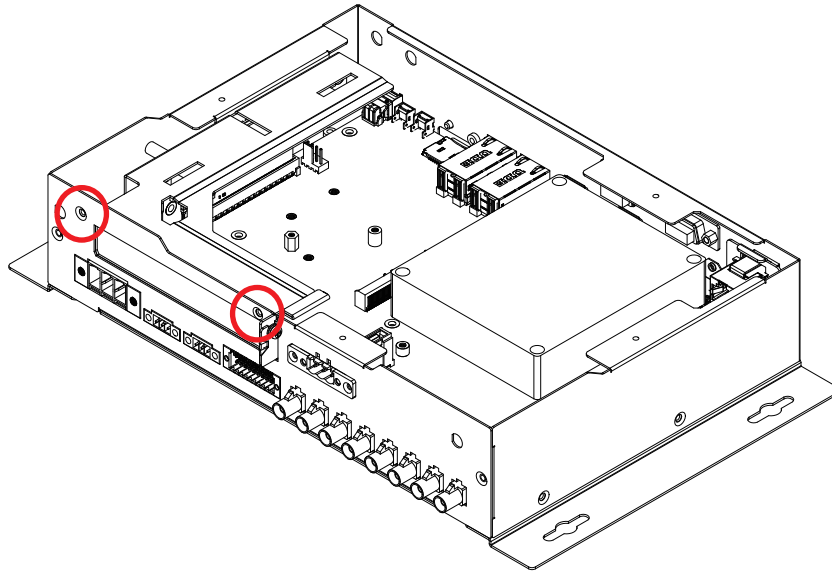

Step 2 Pick up assembly Riser Card.

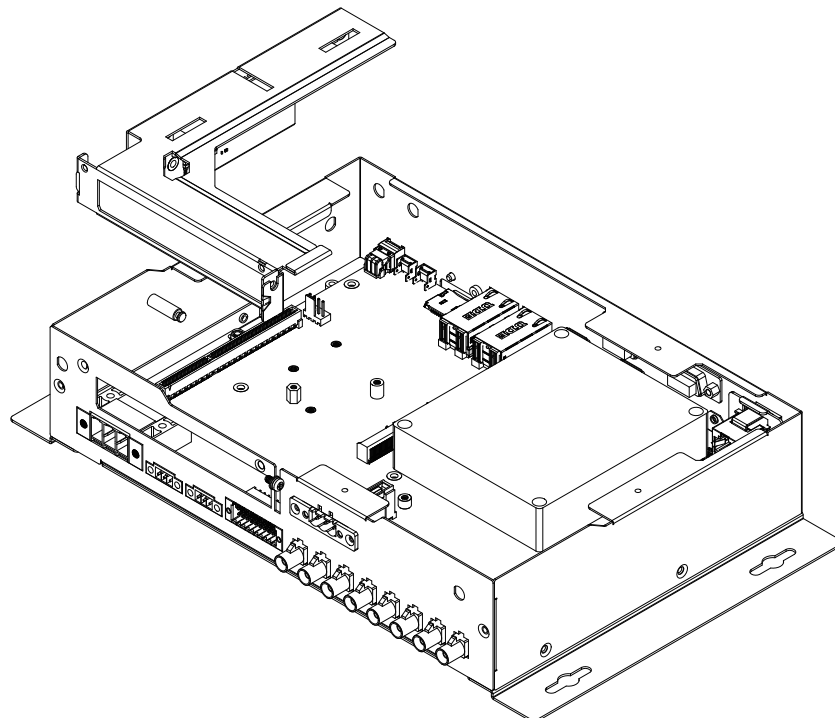

Step 3 Remove the screw indicated and separate I/O bracket from assembly Riser Card.

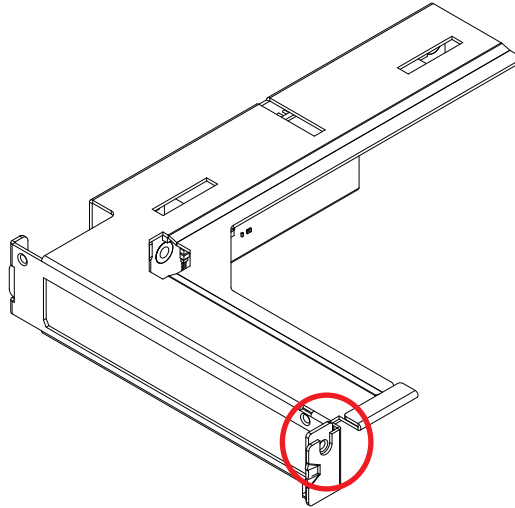

Step 4 Install PCIe card and fasten the screw indicated.

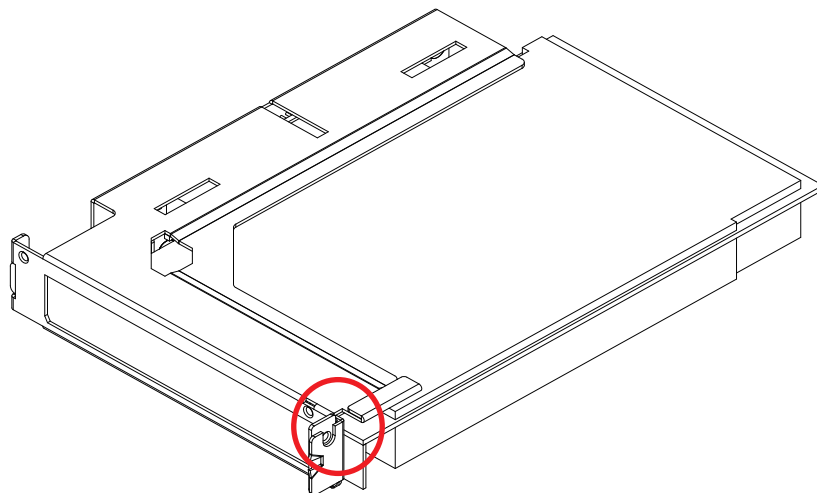

3.5 Installing M.2

3.5.1 M.2 Key E 2230

Step 1 Install M.2 Key E 2230 into slot and fasten one pan head M3x4L screw.

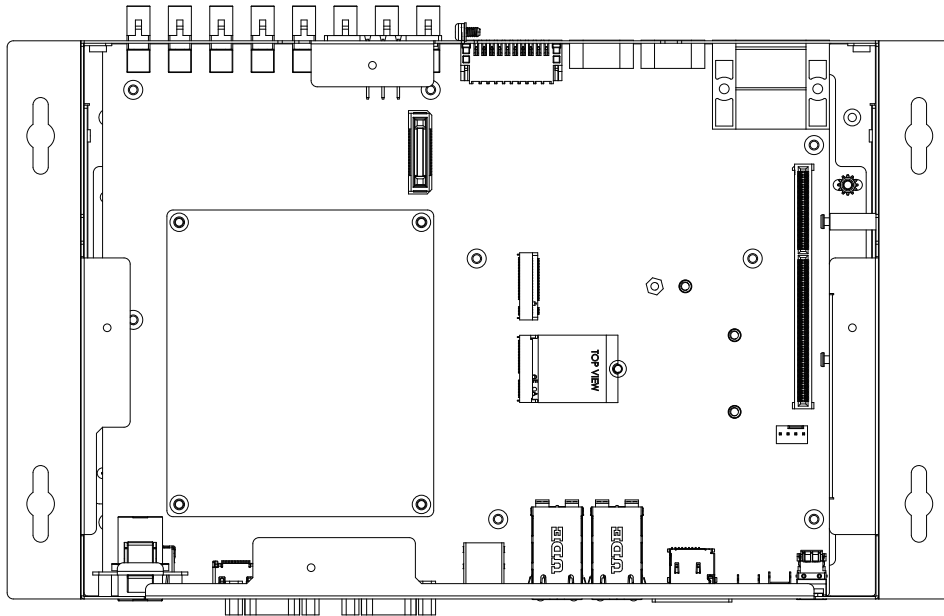

3.5.2 M.2 Key M 2280

Step 1 Remove two F-M3x4L screws on Storage cover.

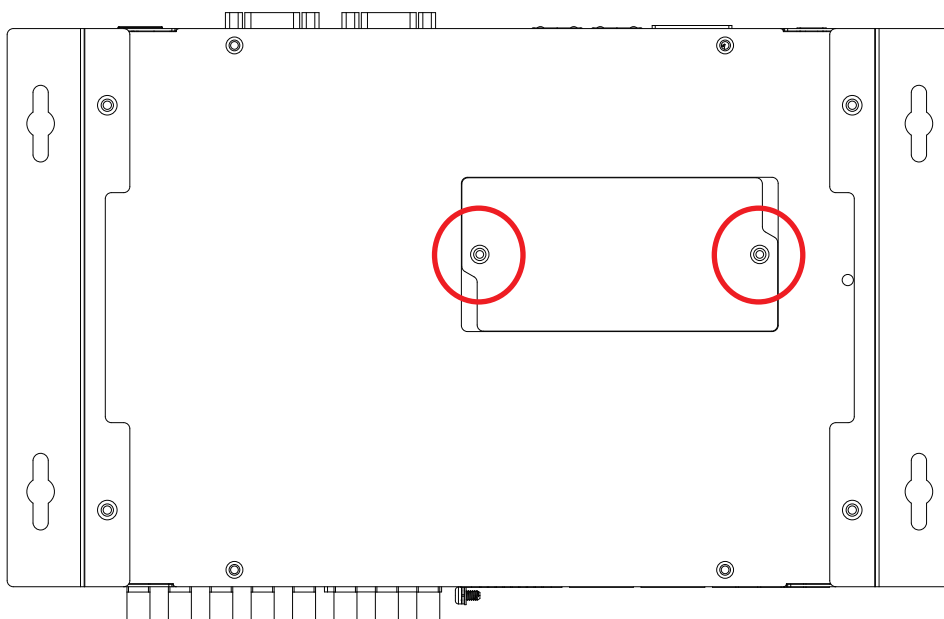

Step 2 Install M.2 Key M 2280 into slot and fasten one pan head M3x4L screw.

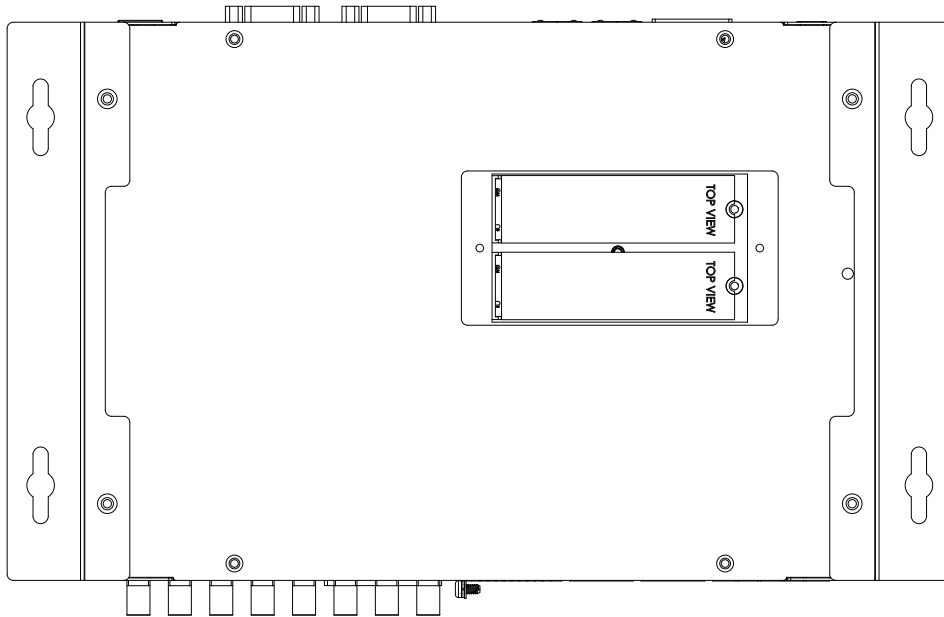

3.5.3 M.2 Key B 2242/3042

Step 1 Install M.2 Key B 2242/3042 into slot and fasten one pan head M3x4L screw.

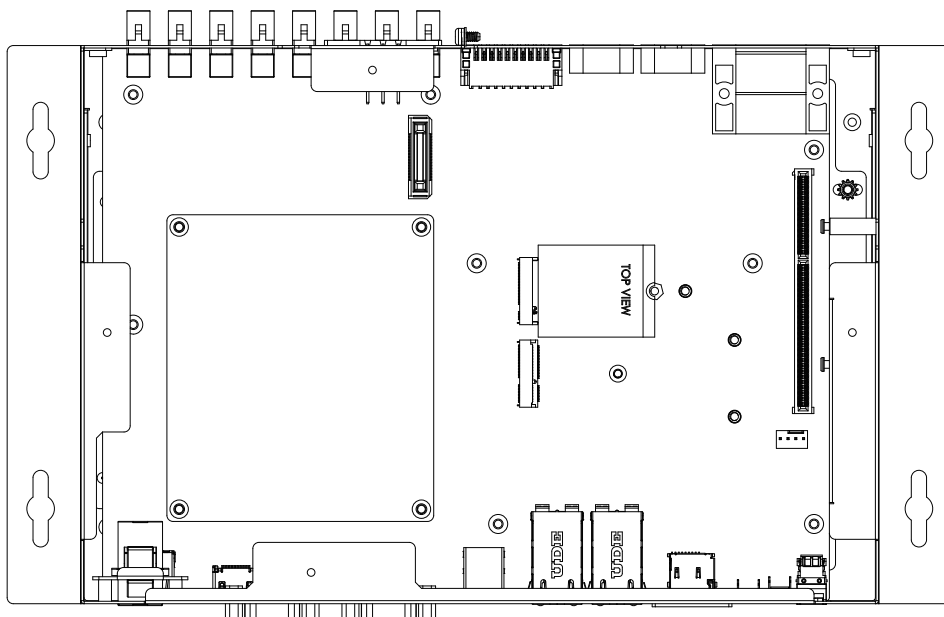

3.5.4 M.2 Key B 3052

Step 1 Change the stud position.

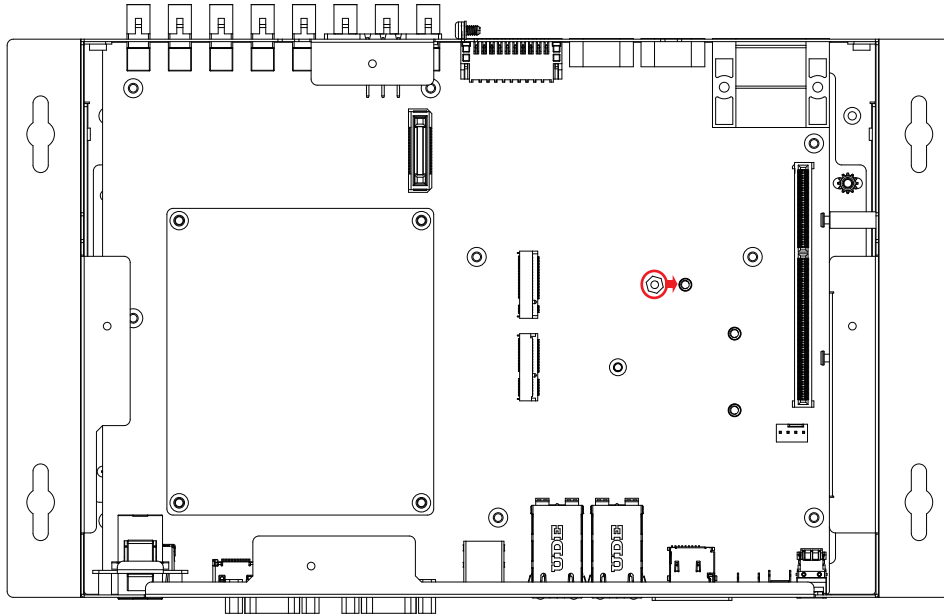

Step 2 Install M.2 Key B 3052 into slot and fasten one pan head M3x4L screw.

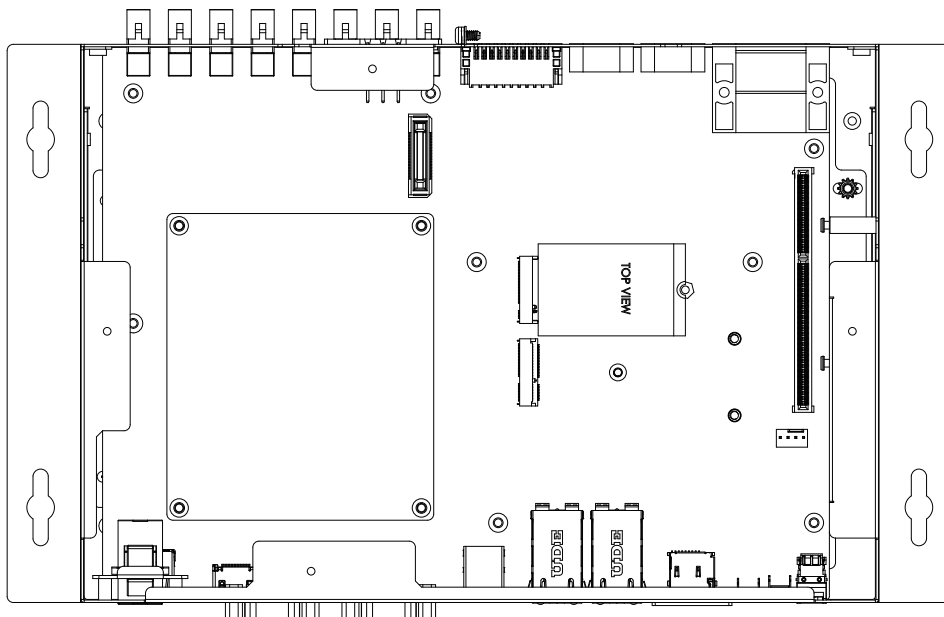

3.6 Installing Antenna Cable

Step 1 Remove the rubber corks on the panel.

Step 2 Put antenna cable connector into the hole on panel.

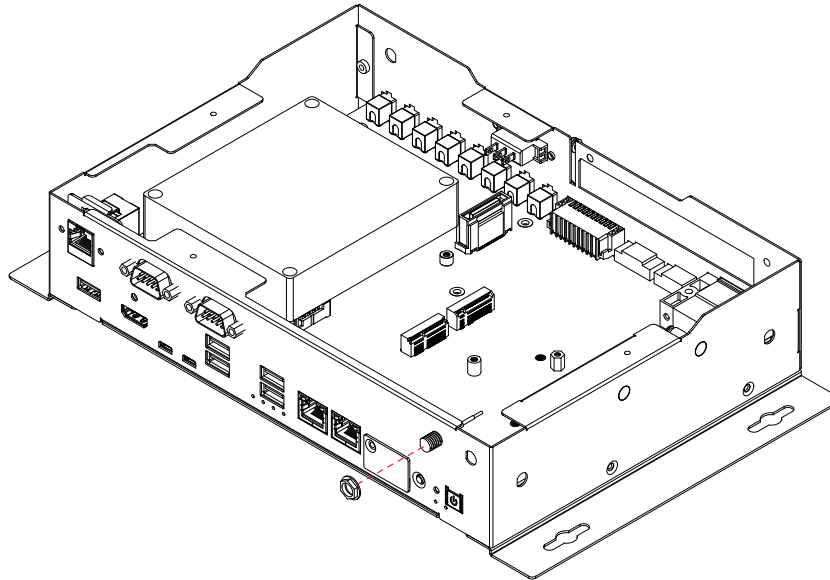

Step 3 Fasten washer on the antenna cable connector.

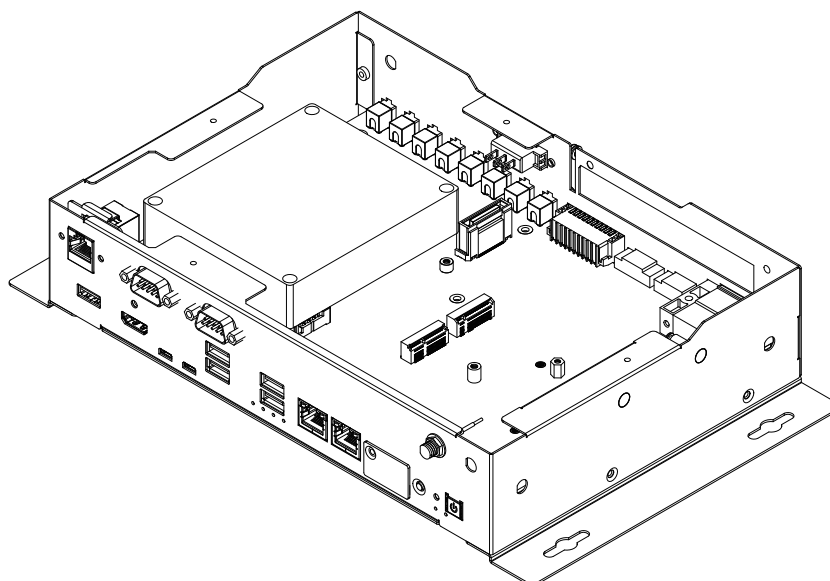

3.7 Mounting Your EAC-5000/EAC-5100

3.7.1 Wall Mount

Install wall mount bracket then fasten four pcs #6-32x6L screws.

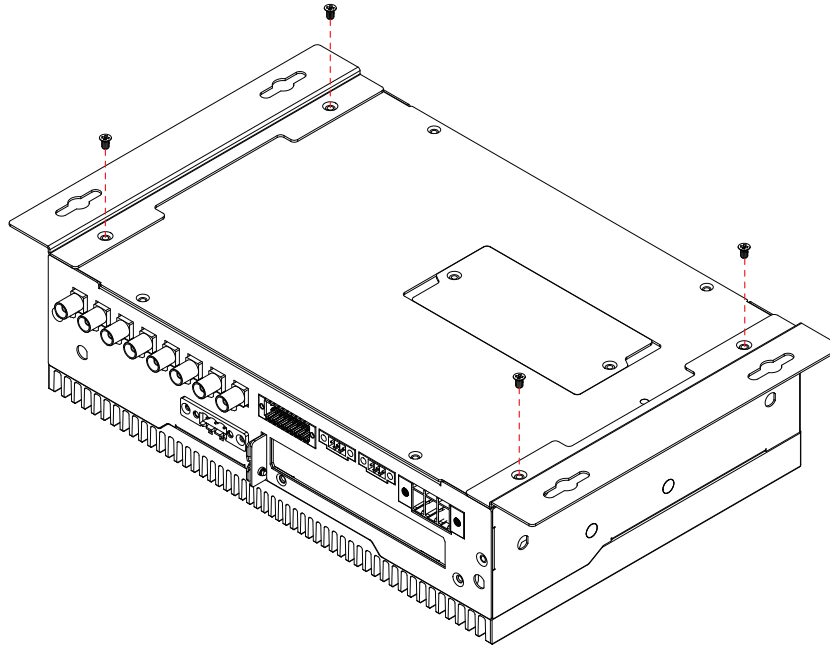

3.7.2 VESA Mount

Install VESA mount then fasten four pcs #6-32x6L screws.

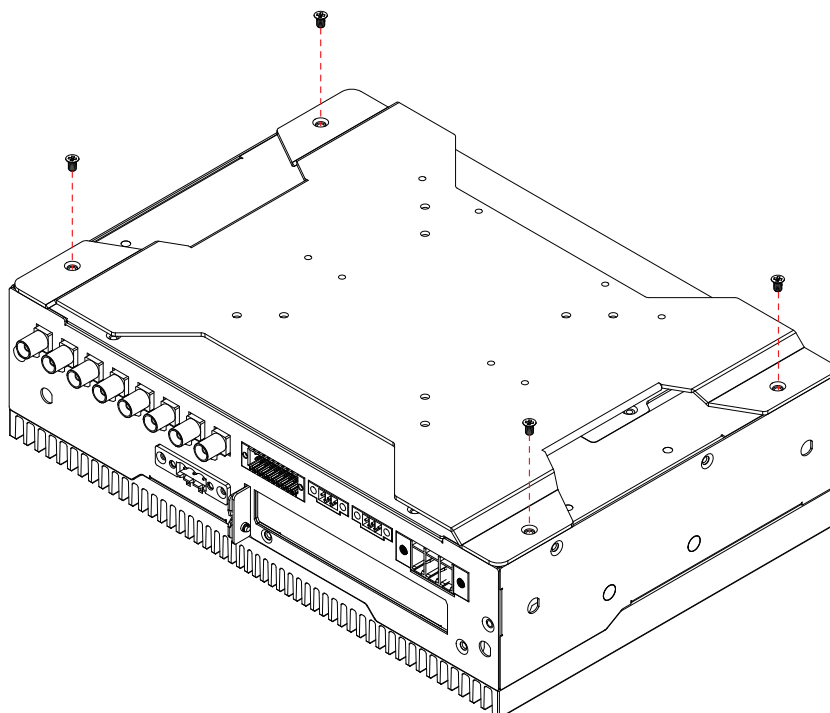

3.7.3 DIN Rail Mount

Install din rail kit then fasten four pcs #6-32x6L screws.

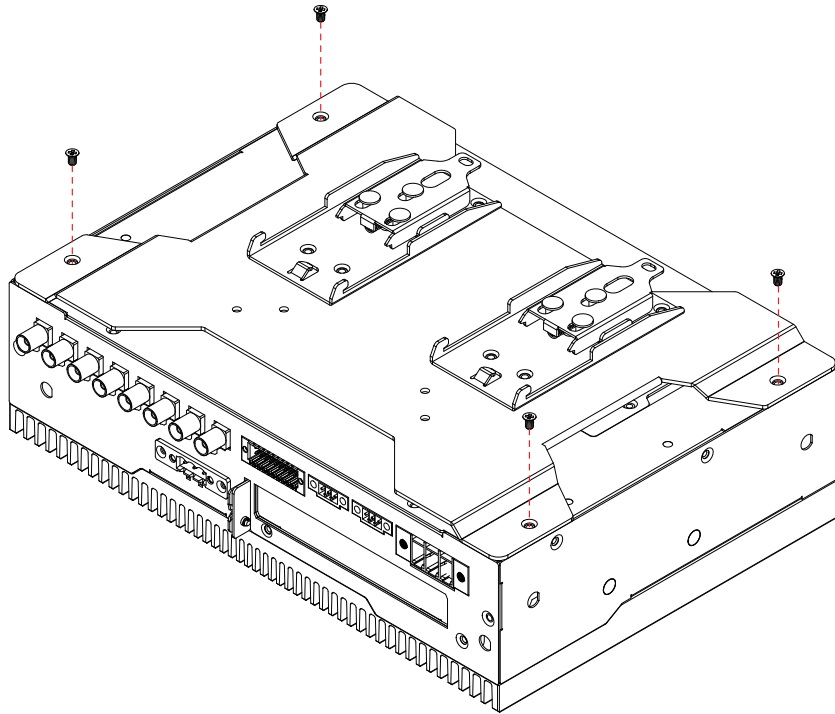

4

SOFTWARE SETUP

4.1 Peripheral Interface Guide

For I/O support and example please follow this link:

https://github.com/VecowSoftware/EAC-5000_IO_Sample

4.2 Flash image to Your EAC-5000/EAC-5100

Before starting the flashing process, be sure the EAC-5000 is turned off and disconnected from the power. You also need to prepare a host computer running Ubuntu 20.04 or later.

4.2.1 Prepare the host computer

Step 1: Open a terminal on host computer and disable the automount of new external storage devices temporarily. On most distributions of Debian-based Linux, you can do this using the following command:

```
$ sudo systemctl stop udisks2.service
```

Step 2: Run the following script to ensure that the host computer has the "nfs-kernel-server" service running:

```
$ sudo service nfs-kernel-server start
```

4.2.2 Download the OS image file to the host computer

Step 1: Download the OS image package file. The file name will be similar to:

```
EAC-5000_64GB_EMMC-B00T_JetPack5.1.1_230731.tbz2
```

Step 2: Check the MD5 Checksum of the OS image package.

```
$ sudo md5sum -c ./EAC-5000_64GB_EMMC-B00T_JetPack5.1.1_230731.tbz2.md5
```

Step 3: Open a Linux terminal on host computer and issue the following command to extract compressed image files:

```
$ sudo tar jxvf ./EAC-5000_64GB_EMMC-B00T_JetPack5.1.1_230731.tbz2
```

4.2.3 Connect EAC-5000 to the host computer

Step 1: Connect the power adapter to the EAC-5000. Connect the Micro USB cable to the “Flash” Port on EAC-5000 and the other end to an available USB port on the host PC. Make sure you have only ONE EAC-5000 device in recovery mode plugged in the host.

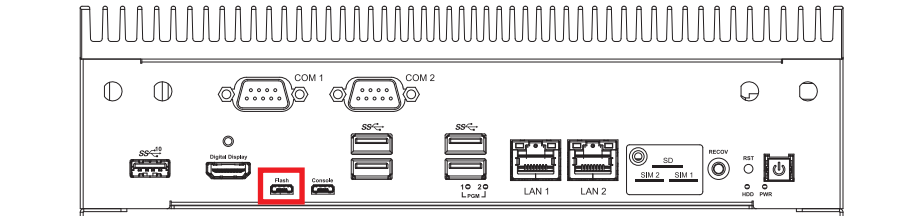

Step 2: Press and hold the “RECOV” button.

Step 3: While holding the “RECOV” button, power on the system. Continue to hold the “RECOV” button for two seconds, and release.

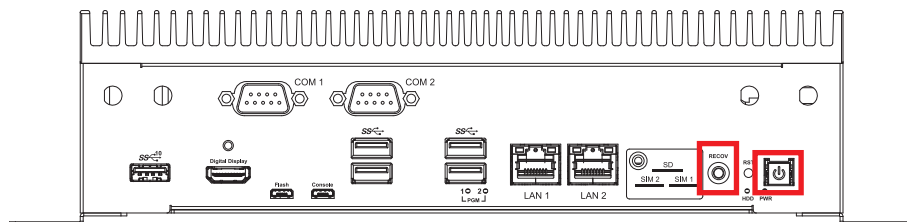

Step 4: Now that the device is in recovery mode, issue “lsusb” command on host PC to find a new USB device:

```
BUS 003 Device 005: ID 0955:7e19 Nvidia Corp.
```

4.2.4 Flash image to the EAC-5000

Step 1: Open a terminal on host PC, then access the package folder you extracted in step 4.2.2-3.

Step 2: Run the following script to install the right dependencies:

```
$ sudo ./14t_flash_prerequisites.sh
```

Step 3: Run this command from the decompressed folder to flash the image:

```
$ sudo ./EAC-5000_flash.sh
```

Step 4: Once the process finished, you should see the following log:

```
Ongoing processes: 11873
Ongoing processes: 11873
Ongoing processes: 11873
Ongoing processes: 11873
Ongoing processes: 11873
Ongoing processes: 11873
Ongoing processes: 11873
Ongoing processes: 11873
Ongoing processes: 11873
Ongoing processes: 11873
Ongoing processes: 11873
Ongoing processes: 11873
Ongoing processes: 11873
Ongoing processes: 11873
Ongoing processes: 11873
Ongoing processes: 11873
Ongoing processes: 11873
Ongoing processes: 11873
Ongoing processes: 11873
Ongoing processes:
Flash complete (SUCCESS)
```

4.3 Software Ignition Control

Vecow provides Ignition Software to control power on/off delay periods.

To activate software ignition control, you need to adjust the **JIGNMODE1** jumper to 2-3, you can access the following path:

```
$ cd /usr/src/tools/EAC-5000/ignition/
```

Or

https://github.com/VecowSoftware/EAC-5000_IO_Sample/tree/master/ignition

to find an application for software ignition control.

4.4 Enable OOB Management Services

This section will guide you step-by-step on how to enable and activate OOB Management Services. If you need to use both services (Allxon INB and OOB features), please follow the steps below.

4.4.1 Enable Allxon INB & OOB Services

4.4.1.1 Install Allxon Agent on Device

Users can easily initiate the Allxon Agent installation process from their desktop using selected devices from Allxon's hardware partners.

Refer to the following webpage for detailed instructions:

[Install Allxon Agent via Command Prompt](#)

4.4.1.2 Pairing Edge Device to Allxon Portal

- Get Device Pairing Code

Refer to the following webpage for detailed instructions:

[Get Device Pairing Code](#)

- Get Add Your Device on Allxon Portal

Refer to the following webpage for detailed instructions:

[Add Your Device on Allxon Portal](#)

4.4.1.3 Enable OOB Enabler on Device

After you have paired and added your device onto Allxon Portal, you will now have the option to also link the OOB Enabler to Allxon Portal.

Refer to the webpage for detailed instructions:

[Enable Out-Of-Band Management on Device](#)

4.4.2 Allxon swiftDR for Power Cycling

Allxon swiftDR Series is a powerful Out-Of-Band remote device management solution to empower disaster recovery. This section details Allxon swiftDR for Power Cycling on Allxon Portal, to introduce Allxon's power-related OOB features.

Refer to the webpage for detailed instructions:

[Allxon swiftDR for Power Cycling](#)

4.5 Troubleshooting Your OOB Enabler

4.5.1 Network Connectivity Requirements

To get the best out of Allxon Services, ensure you are connected to a stable Internet connection. If your organization restricts Internet communications with the network using a firewall or proxy device, refer to the following webpage for detailed Information:

[Allxon Service Port/Protocol and Whitelist Information](#)

A

APPENDIX A : GMSL Camera Guide (EAC-5000 Only)

Before you start

Please connect the camera cable to GMSL port before power on the EAC-5000.

To initialize the GMSL camera, you can access the following path

```
$ cd /usr/src/tools/EAC-5000/camera/
```

Or

https://github.com/VecowSoftware/EAC-5000_IO_Sample/tree/master/camera

to find the camera initial scripts.

B

APPENDIX B : Power Consumption

Testing Board	EAC-5000
RAM	32 GB 256-bit LPDDR5
USB-1	USB Microsoft Wired Keyboard 600
USB-2	USB Mouse HP G1K28AA
USB-3	USB Flash Transcend 3.0 16GB
USB-4	USB Flash Transcend 3.0 16GB
USB-5	ADATA UV128/8GB
Storage	64 GB eMMC 5.1
M.2 KEY E	Intel 8265NGW
LAN 1	1.0 Gbps
LAN 2	1.0 Gbps
Camera	GMSL Camera 8pcs
Graphics Output	HDMI
Power Plan	30W/MAXN
Power Source	Chroma 62006P-100-25
Test Program	Stress-ng Test

B.1 12-core Arm® Cortex®-A78AE v8.2 64-bit CPU, up to 2 GHz 2048-core NVIDIA Ampere™ GPU with 64 Tensor Cores (30W)

Power on and boot to Ubuntu 20.04 LTS 64bit

CPU	Power Input	Ubuntu 20.04 LTS 64bit			
		idle status CPU		Run BurnInTest/Stress-ng Test	
		Max Current	Max Consumption	Max Current	Max Consumption
12-core Arm® Cortex®-A78AE v8.2 64-bit CPU, up to 2 GHz	9V	2.461A	22.14W	5.050A	45.45W
	12V	1.829A	21.94W	3.782A	45.39W
	24V	0.995A	23.88W	1.885A	45.24W
	36V	0.705A	25.39W	1.357A	48.85W
	50V	0.505A	25.26W	1.049A	52.45W

B.2 12-core Arm® Cortex®-A78AE v8.2 64-bit CPU, up to 2 GHz 2048-core NVIDIA Ampere™ GPU with 64 Tensor Cores (MAXN)

Power on and boot to Ubuntu 20.04 LTS 64bit

CPU	Power Input	Ubuntu 20.04 LTS 64bit			
		idle status CPU		Run BurnInTest/Stress-ng Test	
		Max Current	Max Consumption	Max Current	Max Consumption
12-core Arm® Cortex®-A78AE v8.2 64-bit CPU, up to 2 GHz	9V	2.486A	22.37W	6.240A	56.16W
	12V	1.847A	22.16W	4.370A	52.44W
	24V	0.962A	23.10W	2.294A	55.06W
	36V	0.679A	24.44W	1.556A	56.00W
	50V	0.530A	26.50W	1.201A	60.05W



APPENDIX C : Supported Expansion Module List

C.1 Supported 5G/4G/GPS List

Type	Model	Support Standard
M.2 KEY B	Quectel EM06-E	LTE Category 6 Worldwide LTE-A and UMTS/HSPA+ Coverage
M.2 KEY B	Quectel RM500Q-AE	5G sub-6GHz Worldwide 5G and LTE-A coverage
M.2 KEY B	CINTERION Thales_ MV31-W	5G sub-6GHz Global 5G coverage and LTE Cat. 20 fallback GPS, Glonass, Beidou and Galileo

C.2 Supported Wi-Fi/Bluetooth List

Type	Model	Support Standard
M.2 KEY E	SparkLAN_WNFT- 237ACN(BT)	IEEE 802.11a/b/g/n/ac BT5.0
M.2 KEY E	Intel 8265NGW	IEEE 802.11a/b/g/n/ac BT4.2
M.2 KEY E	jjPlus JWW6051	IEEE 802.11a/b/g/n/ac



For further support information, please visit www.vecow.com

This document is released for reference purpose only.

All product offerings and specifications are subject to change without prior notice.

No part of this publication may be reproduced in any form or by any means, electric, photocopying, or recording, without prior authorization from the publisher.

The rights of all the brand names, product names, and trademarks belong to their respective owners.

© Vecow Co., Ltd. 2024. All rights reserved.